

WPW PROFESSIONAL CUTTING TOOLS

For Machining Traditional & Advanced Materials

Wood, Composites, Aluminum, Plastics & more



 **WPW**
CREATIVE CUTTING SOLUTIONS

Since 1959

A Word from the Founder

I have been involved in metalworking since I was a boy working in my father's machine shop before World War II. In 1959 I started a small factory with 2 partners, which later became W.P.W. Engineering and is now run by the 2nd generation.

We were the first company in Israel to produce Carbide Tipped Router Bits and we have gained tremendous experience over the years, giving professional solutions to cutting and drilling problems.

W.P.W. Engineering has grown to be a leading manufacturer of Carbide Router Bits and other quality tools for woodworking. Thanks to our experienced workers and constant improvements in our production process, we have achieved high quality, reliability and fast delivery of our stock items.

WPW exports its products to North America, Western and Eastern Europe, South Africa, Australia and more. We have been selling our tools under private labels in the USA for over 40 years.

There is no compromise in production quality and the quality of materials used. Our customers know and appreciate this and therefore are very loyal to WPW. You may find cheap tools on the market, but as the old saying goes: "we are not rich enough to buy cheap..."

WPW high quality tools (some of our customers say - the best quality) give excellent value for your money.

You are most welcome to be our partner and join the WPW family with full trust for long-term cooperation.



A handwritten signature in blue ink that reads "Chanan Werebeychick". The signature is fluid and cursive, written on a white background.

Chanan Werebeychick
President

QUALITY

WPW offers high quality tools, designed for efficient cutting and long tool life. Compliance with our own specifications is guaranteed by strict quality control used throughout the manufacturing process. Our sophisticated computer controlled machines contribute to this process.

The quality control system assures us accurate dimensions, concentricity, correct cutting angles, quality of grinding, brazing, etc.

Woodpecker Router Bits are made with Anti Kickback design according to safety requirements of the German Woodworking Trade Association. BG-TEST approval No. 159-000.



All tools are guaranteed against any defects in either workmanship or material. We will not guarantee tools that have been misused or have been damaged due to improper maintenance.

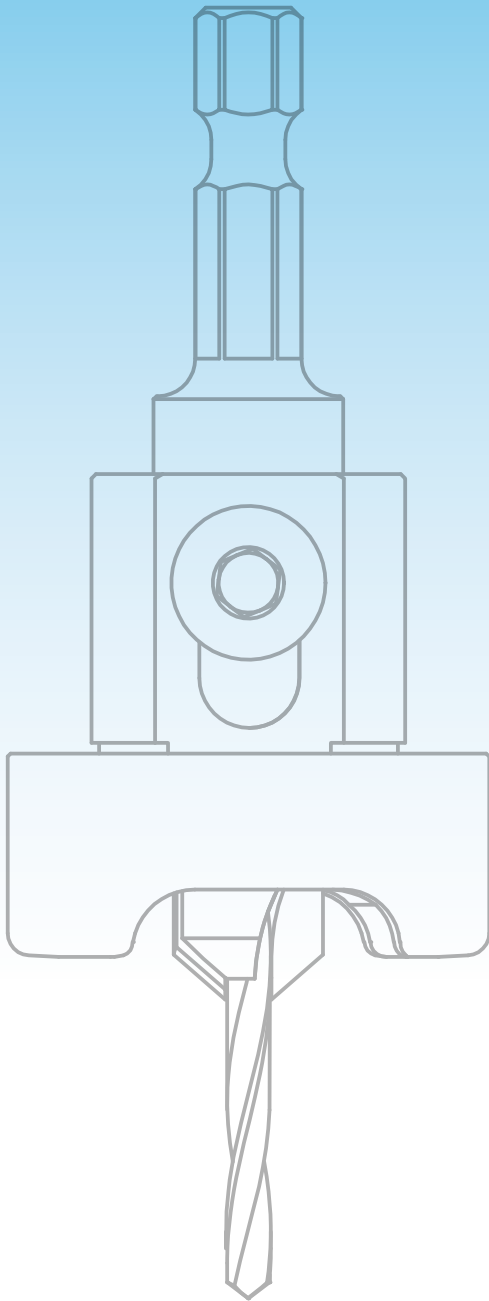

■	Index by Tool Profile	5
■	Drilling & Countersinking	8
■	Industrial Drilling	20
■	Diamond Router Bits	25
■	Professional Router bits	28
■	WoodPecker Router Bits	73
■	Replacement Parts	78
■	Technical Information	82
□	Alphabetical Index	86

Don't miss WPW's innovative solutions

WPW has added many new tools and creative ideas which you will find throughout this catalogue, marked with the special logos as follows:



Unique tools which deserve special attention. Among them: Countersinks with revolving Depth Stoppers, Stepped Drills, Drill adapters; As well as Router Bits with 3 and 4 flutes, Miniature Router Bits with 1/8" shank, Multi Trimmers etc.



Tools with hard K-Carbide grade - perfect for CNC routing and router table jobs. Excellent for cutting MDF and other hard material. Up to 200 % longer lifetime when cutting abrasive materials.



NANO Router Bits with 4.8mm (Miniature) Ball Bearing guide - Smallest in the market. These tools allow access to those tight spaces and sharp corners where regular tools won't go.



WPW CREATIVE CUTTING SOLUTIONS

Upgrade your decking job-Use WPW solution

Professional Countersink & Stop system

Pre-drilling & Countersinking is essential in order to achieve Perfect results in Decking.

Unique designs with simple depth control of both the drill and the countersink simplifying the job.

No scratches! No burn marks!

Page: 11-12



Mission Impossible? Not Anymore

Mini Straight Template Bits can do it!

At last, top bearings can be of the same Diameter as the shank, or even smaller. Templates can be produced the same size as the finished workpiece. A very important feature on routing complex shapes when small cutters are needed.

Page: 40

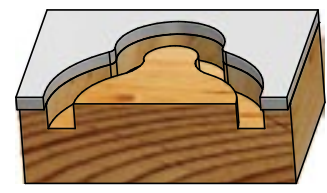

Pilot hole, Clearance hole and Countersink in one operation

Countersinks with Stepped Drills

No need to compromise any longer

Page: 10

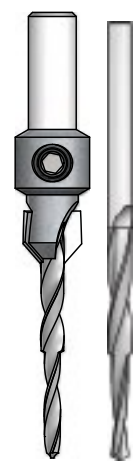
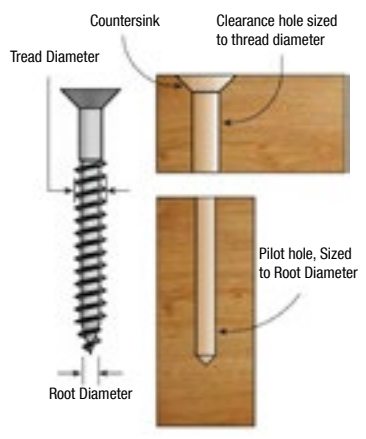

Smaller Bearing and Smaller Cutter

NANO Router Bits - When Size Matters



4.8mm Ball Bearing guide - Smallest in the market. Look for the NB logo and find a selection of profiles. You now have access to those tight spaces and sharp corners where regular tools won't go.

Page: 40, 42, 45, 47, 60, 63

35 mm Hinge Boring bits with depth-stopper

Prevents damaging the door.

Simple depth control.

Page: 15



And Smaller Shank too

TCT Router Bits with 1/8" Shank

For CNC Routers, Dremel and equivalent rotary machines.

Page: 30, 40, 42

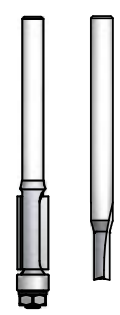

**More Cutters / Flutes
Better Surface Finish and
Longer Tool life!**



3 & 4 Flute bits - a comprehensive selection of unique tools.

Eliminate the time-consuming hand-filing and sanding that normally follows routing with 2 fluted tools in hard materials.
Page: 34, 39, 41, 43, 47, 49, 64

**One tool - many applications
Slot & Undercut Bit with
Variable Depth**

For general Slotting and undercutting. Suitable for flooring. Exchangeable bearings enable different depths of cut. Available with 3mm, 4mm, 5mm and 6mm slotting cutters.

Can be used in CNC (with no bearing) or in router machine.
Page: 71

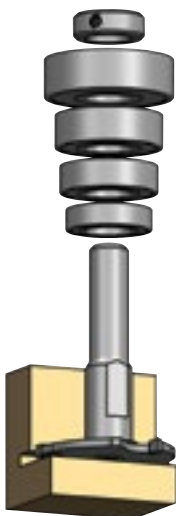

Longer Tool Life and Better Surface Finish!

K Bits – Harder Carbide for cutting abrasive materials



Cost effective - up to 200% longer life time. Excellent for Routing Laminated materials like MDF and HDF. Developed especially for working on materials that consist of synthetic polymer resins for bonding purposes.

More Straight Router Bits and Flush Trim Bits can now be ordered with harder K-Carbide.

Search for the /K sign.

Diamond Tipped PCD Router Bits

Designed for CNC machines, these tools last 30- 50 times longer than Carbide tipped tools. Very efficient in cutting a wide variety of tough abrasive materials including composites, particleboard, MDF (either raw or laminated), HPL, veneers and hardwoods.

Page: 26

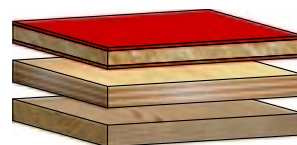

Need a longer Tool but cannot find?

Shank Extension Adapters

For CNC and Router machines. Allows deeper reach for wide range of applications. Very useful when the bit is too short for the job.
Page: 79



**More Applications
Diamond Coated
Router Bits**

For cutting Fiberglass, Carbon Fiber and other Composite material.
Page: 27



Engraving Bits with Mirror Finish Carbide

For sign making and PCB milling. Used with CNC and industrial engraving machines for wood, plastic, brass, aluminum, copper and different composites.
Page: 52



Drilling and Countersinking

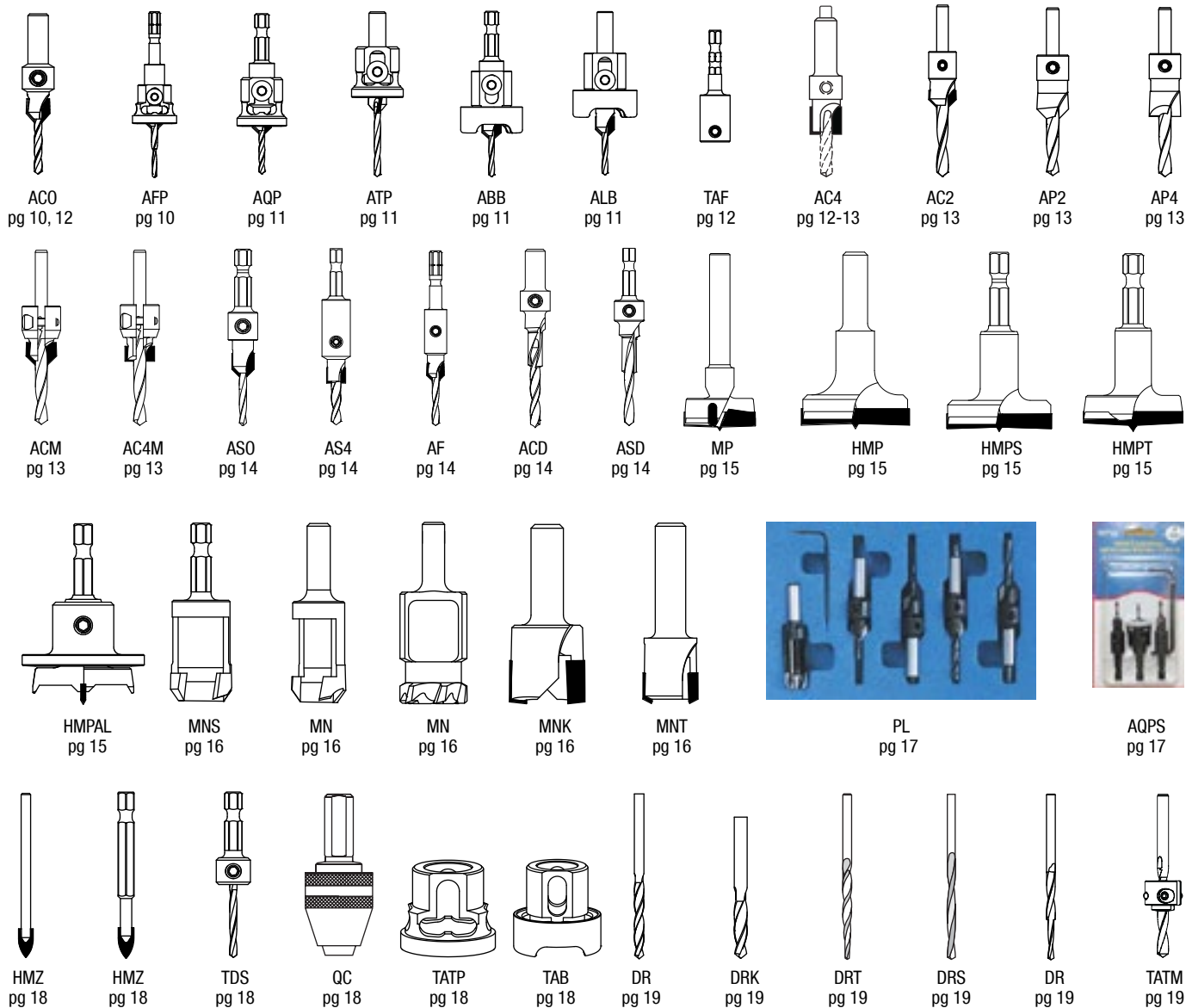

Industrial Drilling

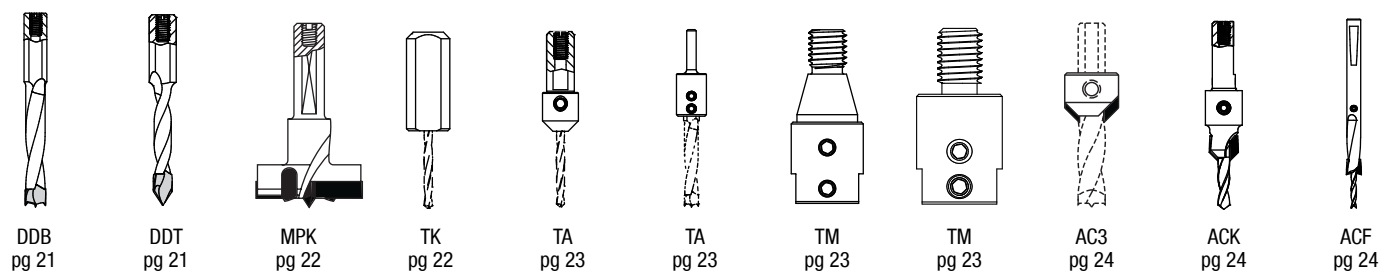

Diamond Router Bits

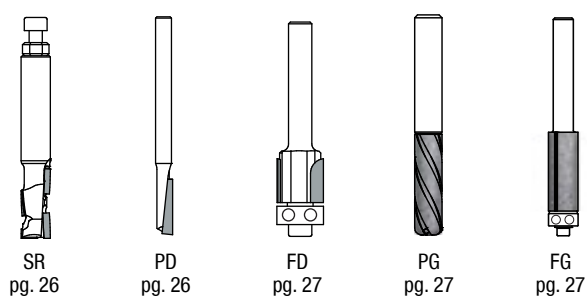

Professional Router Bits

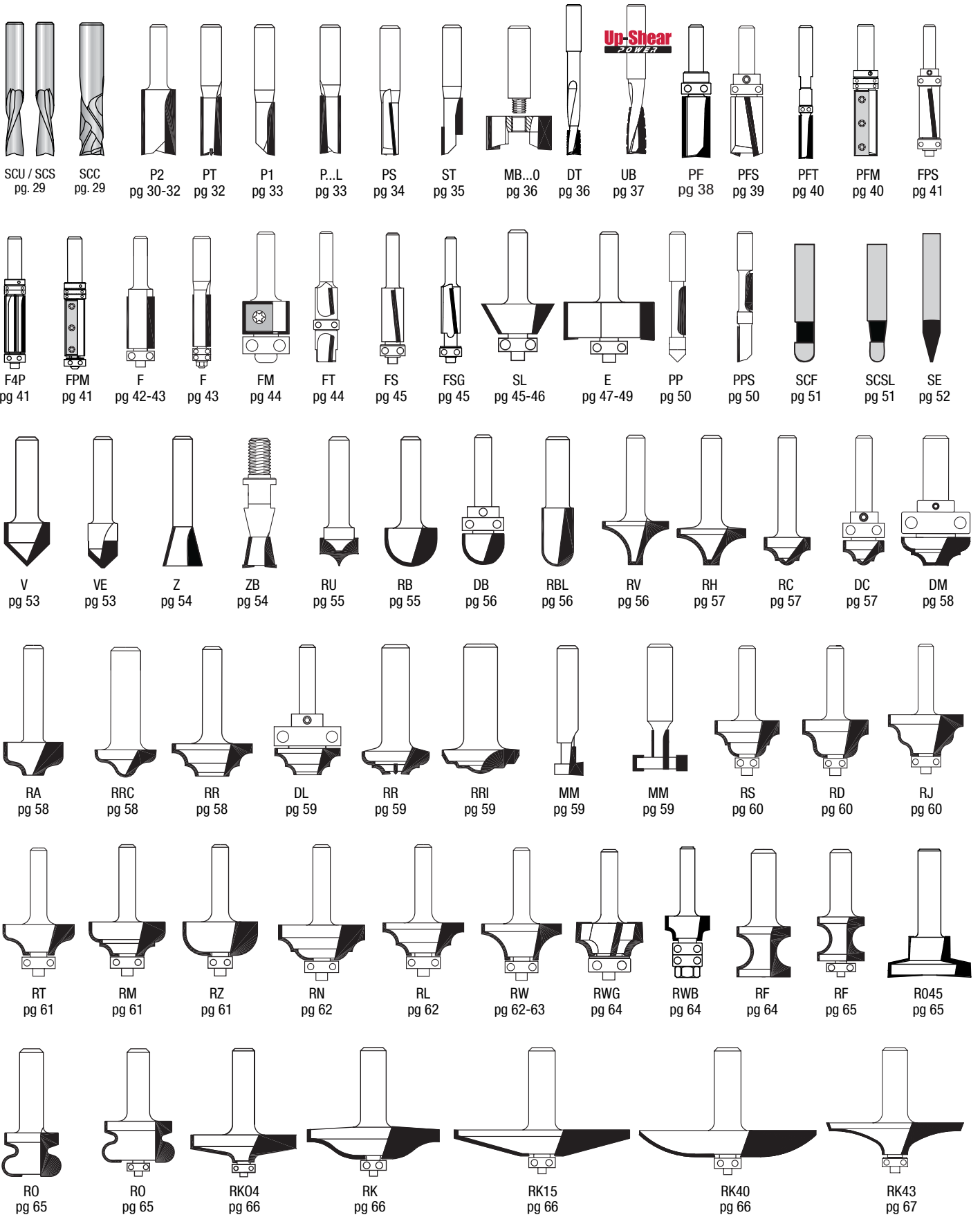

Professional Router Bits

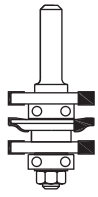

RGD2
pg 67

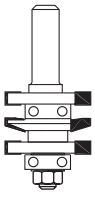

RGD5
pg 67

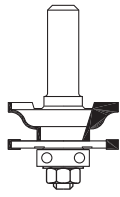

RG1
pg 68



RG2
pg 68

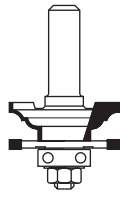

RG3
pg 68



RG5
pg 69



RG6
pg 69

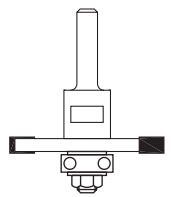

N
pg 69

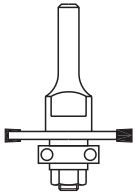

NB
pg 70



NBS
pg 70



NBC
pg 70

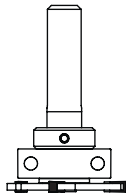

NUS
pg 71

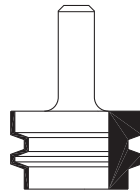

FJ2
pg 72

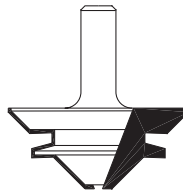

FJ4
pg 72

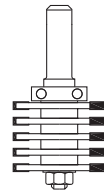

FJ5
pg 72

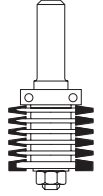

FJ6
pg 72



HP
pg 74



HF
pg 74



HPF
pg 74

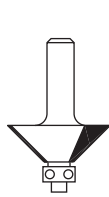

HSL
pg 75

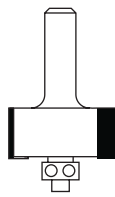

HE
pg 75



HZ
pg 75

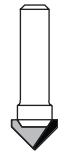

HV
pg 76

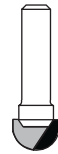

HRB
pg 76

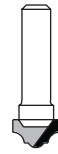

HRC
pg 76



HRD
pg 76

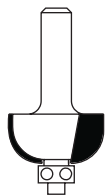

HRZ
pg 76

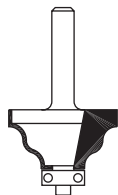

HRJ
pg 76



HRW
pg 77



HS06
pg 77



SA
pg 77

Replacement Parts



TX
pg 79



T
pg 79



B
pg 80



BD
pg 80



PF..
pg 80

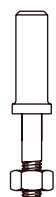

N
pg 80



BR/BT
pg 81

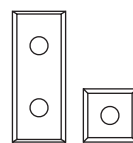

CM
pg 81

DRILLING & COUNTERSINKING

WPW tips will help you to understand the issue of joining wood with screws and avoid the problem of wood cracking in decking and other joinery exterior and interior applications.

Innovative tools such as special stepped drills, Countersink & Stop and “Plug Sets”.

The tools are offered with round shank as well as with shanks that fit Quick-Change systems - 1/4” (6.3mm) hexagonal shank for standard system and special tools compatible with Festool® CENTROTEC® system.



JOINING WOOD WITH SCREWS NOT SUCH A SIMPLE JOB.

WPW tips will help you to understand this issue and avoid problems such as wood cracking

When joining 2 pieces of wood using screws, it is essential to predrill and countersink in order to achieve an esthetic and long lasting finish.

- Pilot hole - in the bottom board.
 - Clearance hole and Countersink - in the top board.
- The pilot hole diameter should roughly match the root diameter of the screw. It can be slightly smaller for softwood.
- The clearance hole should be slightly larger than the diameter of the threads. For decking jobs, it is not usually necessary to pre-drill the bottom board, as it will always be hidden from view.

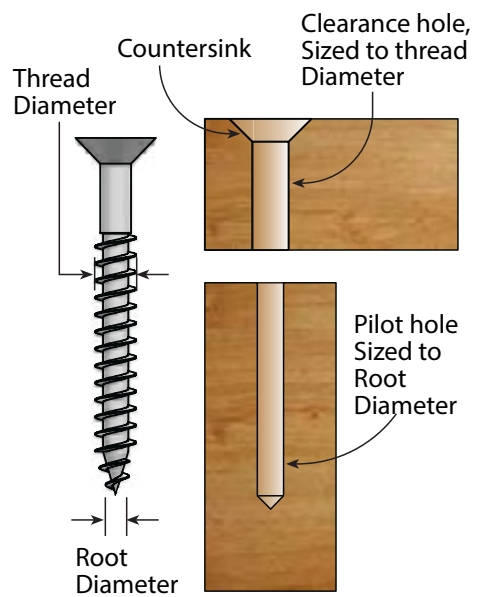

Skipping the predrilling process

This might cause splitting and cracking of the wood or even breakage of the screw when using hardwood or composite materials. This failure can appear immediately after driving the screw, or after a certain period, due to not enough room for the wood to expand and contract as moisture levels in the wood change due to it being exposed to the weather.

Avoid cracking - always predrill before driving a screw!

WPW!
We need your help!

No problem! Use WPW Countersink & Stop.

Drilling a clearance hole and countersink

Clearance hole ensures a tight joint, allowing the screw to pass freely through the top board. The screw engages only the bottom board. Hence, the upper board is pulled down to the bottom board.

Countersink is needed to set screws flush or below the surface of the board!

Depth-Stop helps to always achieve the same depth of the countersink.

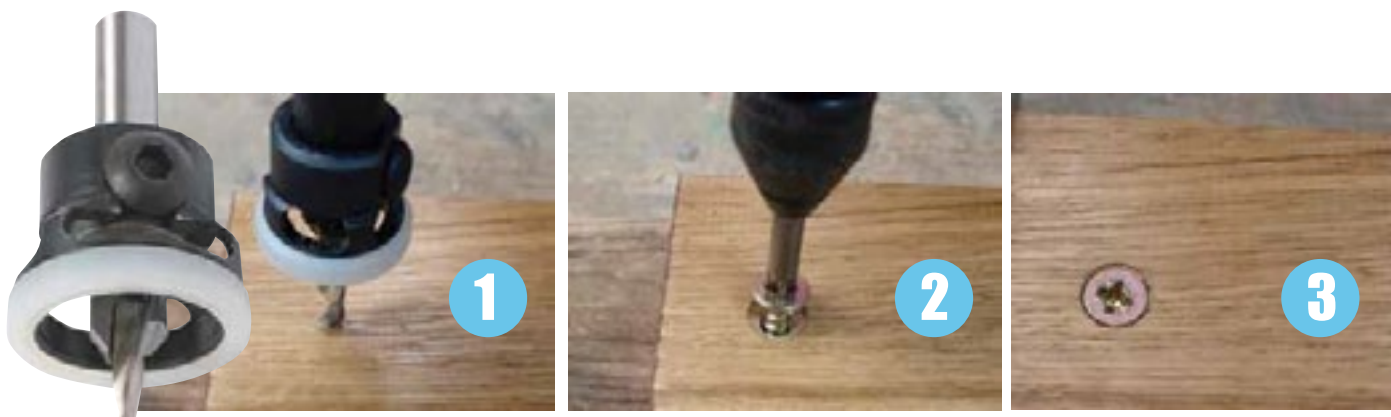

WPW Countersink & Stop for a long lasting perfect joint.



WPW Adjustable Depth Stopper guarantees uniform depth

Drill Diameter VS Screw size

We are often asked: "Which drill should I use for a specific screw?"

The answer is not simple because of the difference between the Pilot hole Dia. and the Clearance hole Dia.

Different applications require different holes:

1. For standard woodworking – Countersink, Clearance hole and Pilot hole. Use stepped drills.
A reasonable alternative would be taper point drills.
2. Decking – Only Countersink and Clearance hole. Not necessary to pre-drill the bottom board, as it will always be hidden from view.
3. Attaching furniture fittings like hinges – Only Pilot hole is needed.

WPW Stepped drills. The ultimate solution is now available

Use the following table for matching between the stepped drills and the screw size / Screw No.

Drill No.	Clearance Hole Dia.	Pilot Hole Dia.	Total Length	Step Length	Suggested Screw size		Suggested Screw No	
	D	D1	L	L1	S/W	H/W	S/W	H/W
	mm	mm	mm	mm				
DR24036	3.6	2.4	70	16	3.5MM	3MM	#6	#5
DR28040	4	2.8	75	19	4MM	3.5MM	#8	#6
DR32044	4.4	3.17	80	22	4.5MM	4MM	#9-10	#8
DR35050	5	3.5	86	25	5MM	4.5MM	#12	#9-10

S/W = Soft wood

H/W = Hard Wood

Drill a smaller hole for soft wood - roughly 10-15% smaller.

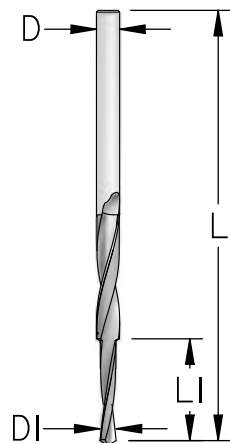

Carbide Tipped Countersinks with Stepped Drills

ACO...M

Carbide Tipped Countersink

Stepped HSS drill included. Round shank.

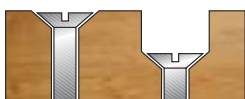

Tool No.	D1	D2	D	L	d
AC03605M	3.6	2.4	10	44	8
AC04005M	4	2.8	10	44	8
AC04405M	4.4	3.2	11.1	44	8
AC05007M	5	3.5	12	51	9.5

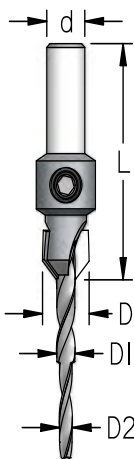

AFP...M

Countersinks with Low Friction Depth-Stopper

Compatible with Festool® CENTROTEC® system

Stepped HSS drill included.



Tool No.	D1	D2	D	L
AFP3604M	3.6	2.4	9.5	74
AFP4004M	4	2.8	9.5	74
AFP4404M	4.4	3.2	12.0	77
AFP5004M	5.0	3.5	12.7	77

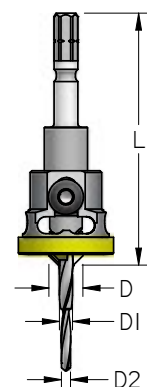



CARBIDE TIPPED COUNTERSINK WITH DEPTH-STOP

For clean surface and simple depth control. No scratches! No burn marks!

Unique adjustable depth-stops, developed for quick and easy adjustment of the countersink depth. The user-friendly design enables easy control of the drill length and its replacement. Disassembly of the Depth-Stop is not needed. Special double-sided hex key (1/8" x 4) included.



AQP

Countersink with Low friction Depth-Stop

Antifriction polymer Collar. HSS drill included.
Quick-Change 1/4" (6.3mm) HEX shank.

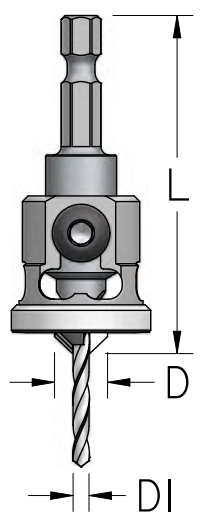

Tool No.	D1	D	L
AQP2004S	2	9.5	60
AQP2404S	2.4	9.5	60
AQP2504S	2.5	9.5	60
AQP2804SC	2.8	9.5	60
AQP3004SC	3	9.5	60
AQP3204SC	3.2	9.5	60
AQP3604SC	3.6	12.7	60
AQP4004SC	4	9.5	60
AQP4014SC	4	10	60
AQP4504SC	4.5	9.5	70
AQP5004SC	5	12.7	70
AQP6004SC	6	12.7	70

ATP

Countersink with Low friction Depth-Stop

Antifriction polymer Collar.
Round shank. Slow Spiral HSS drill included.

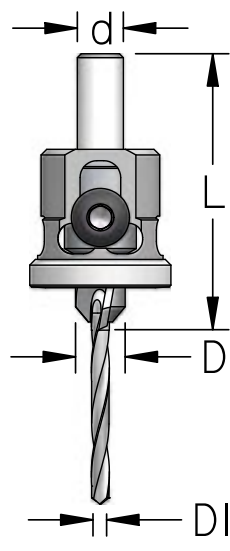

Tool No.	D1	D	L	d
ATP2405D	2.4	8.5	49	8
ATP2505D	2.5	8.5	49	8
ATP3005D	3	10	49	8
ATP3205D	3.2	9.5	49	8
ATP3285D	3.2	12.7	51	8
ATP3505D	3.5	10	49	8
ATP3605D	3.6	10	49	8
ATP4005D	4	10	50	8
ATP4405D	4.4	11.1	50	8
ATP4807D	4.8	11.1	51	9.5
ATP4817D	4.8	12.7	51	9.5
ATP5005D	5	10	50	8
ATP5007D	5	12	51	9.5
ATP6007D	6	12.7	51	9.5

ABB

Countersink & Stop PRO

Non-Friction metal stopper with thrust ball bearing.

Assures a strong and long lasting tool.
Efficient and easy chip evacuation.
Quick-Change 1/4" (6.3mm) HEX shank.
HSS drill included.

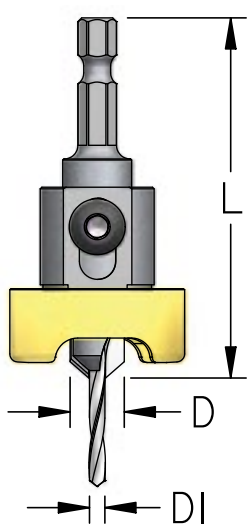

Tool No.	D1	D	L
ABB2404S	2.4	9.5	66
ABB3204S	3.2	9.5	66
ABB3604S	3.6	9.5	66
ABB4004SC	4	9.5	66
ABB4404SC	4.4	12.7	70
ABB4504SC	4.5	12	70

ALB

Countersink & Stop PRO

Non-Friction metal stopper with thrust ball bearing.

Assures a strong and long lasting tool.
Efficient and easy chip evacuation.
Round shank.
Short HSS drill included.

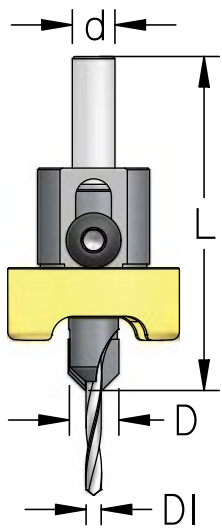

Tool No.	D1	D	L	d
ALB5017SC	5	10	65	10
ALB5007SC	5	12	65	10
ALB6007SC	6	12.7	65	10



Countersink Adaptors

Fits most standard WPW Countersinks and counterbores with 8mm shank

TAC

Round Shank Adapter with Depth-Stop

No scratches! No burn marks!

Combines the professional TCT standard WPW countersinks and counterbores (8mm shank), with WPW unique adjustable depth-stoppers. User-friendly design enables easy control of the drill length and its replacement. Special double-sided hex key (1/8" x 4) included.



Tool No.	Stopper	Shank
TACB806	Non-Friction	Ø9.5 mm
TACP806	Low-Friction	Ø9.5 mm

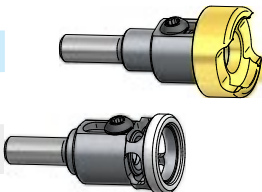

TAF080H

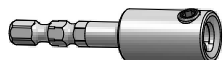

Adapter with Hybrid shank

Fits both Festool® CENTROTEC® drill machines and standard quick-change chucks for 1/4" (6.3mm) HEX shank.

At last you can use WPW professional TCT countersinks and counterbores (8mm shank), in almost any drilling machine.

ACO...D

Carbide Tipped Countersink

Slow Spiral HSS drill included.
Round shank.

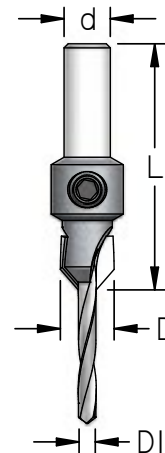

Tool No.	D1	D	L	d
AC02405D	2.4	8.5	44	8
AC02805D	2.8	9.5	44	8
AC03005D	3	10	44	8
AC03215D	3.2	8	44	8
AC03205D	3.2	9.5	44	8
AC03285D	3.2	12.7	49	8
AC03605D	3.6	10	44	8
AC04005D	4	10	44	8
AC04405D	4.4	11.1	44	8

Tool No.	D1	D	L	d
AC04807D	4.8	11.1	51	9.5
AC04817D	4.8	12.7	49	9.5
AC05007D	5	12	51	9.5
AC05607D	5.6	12	47	9.5
AC05617D	5.6	12.7	49	9.5
AC06007D	6	12.7	47	9.5
AC06317D	6.3	12.7	47	10
AC06307D	6.3	13.5	47	10

ACO...T

Carbide Tipped Countersink

Taper Point HSS drill included.
Round shank.

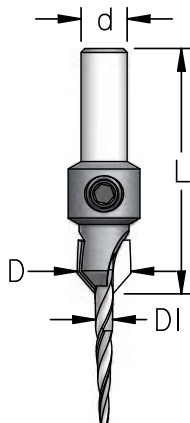
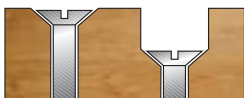

Tool No.	D1	D	L	d
AC03205T	3.2	9.5	44	8
AC03605T	3.6	10	44	8
AC04005T	4	10	44	8
AC04405T	4.4	11.1	44	8
AC04807T	4.8	11.1	51	9.5

AC4...D

Carbide Tipped Counterbore (flat bottom)

Slow Spiral HSS drill included. Round shank.

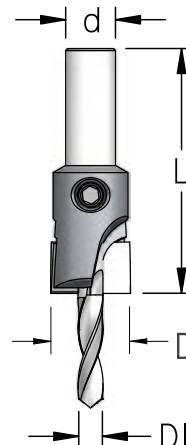
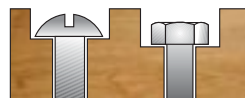

Tool No.	D1	D	L	d
AC43205D	3.2	9.5	48	8
AC44005D	4	10	48	8
AC44405D	4.4	10	48	8
AC44817D	4.8	12.7	48	9.5
AC45617D	5.6	12.7	48	9.5
AC46017D	6	12.7	48	9.5
AC46317D	6.3	12.7	48	9.5

AC2/AS2

Carbide Tipped Countersink - Shankless

Slow Spiral
HSS drill included.

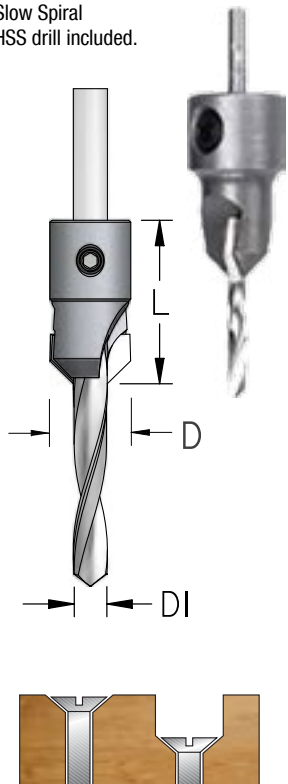

Tool No.	D1	D	L
AS22800D	2.8	9.5	28
AS23000D	3	9.5	28
AS23200D	3.2	9.5	28
AC21232D	3.2	12.7	32
AS23500D	3.5	9.5	28
AS23600D	3.6	9.5	28
AS24000D	4	9.5	30
AC21240D	4	12.7	32
AS24400D	4.4	9.5	30
AS24810D	4.8	12.7	30
AC21648D	4.8	16	32
AS25610D	5.6	12.7	30
AC21656D	5.6	16	32
AS26310D	6.3	12.7	30
AC26320D	6.3	16	32
AC27020D	7	16	39
AC28020D	8	16	39
AC28030D	8	19	39
AC29530D	9.5	19	39
AC22595D	9.5	25.4	52
AC22811D	11.1	28.6	52

AC4

Carbide Tipped Counterbore - Shankless

Slow Spiral HSS drill included.

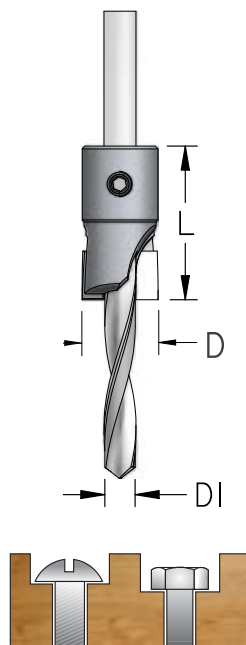

Tool No.	D1	D	L
AC49540D	4	9.5	32
AC49548D	4.8	9.5	32
AC41248D	4.8	12.7	32
AC41648D	4.8	16	32
AC41263D	6.3	12.7	32
AC46320D	6.3	16	32
AC41963D	6.3	19	38
AC42263D	6.3	22.2	38
AC47020D	7	16	38
AC48020D	8	16	38
AC48030D	8	19	38
AC49530D	9.5	19	38
AC42595D	9.5	25.4	51
AC42512D	12.7	25.4	51
AC42812D	12.7	28.6	51

AP2

HS Countersink - Shankless

Slow Spiral HSS drill included.

Tool No.	D1	D	L
AP21232D	3.2	12.7	32
AP21240D	4	12.7	32
AP21648D	4.8	16	32
AP21656D	5.6	16	32
AP21663D	6.3	16	32
AP21980D	8	19	38
AP22595D	9.5	25.4	38

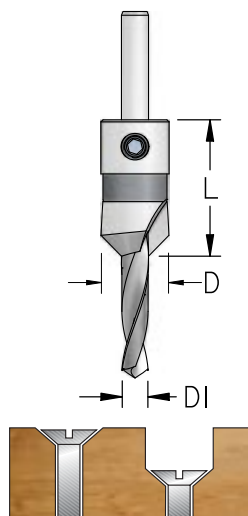

AP4

HS Counterbore - Shankless

Slow Spiral HSS drill included.

Tool No.	D1	D	L
AP49540D	4	9.5	32
AP41248D	4.8	12.7	32
AP41648D	4.8	16	32
AP41263D	6.3	12.7	32
AP41663D	6.3	16	32
AP41963D	6.3	19	38
AP41695D	9.5	16	32
AP42595D	9.5	25.4	51
AP42512D	12.7	25.4	51
AP42812D	12.7	28.6	51

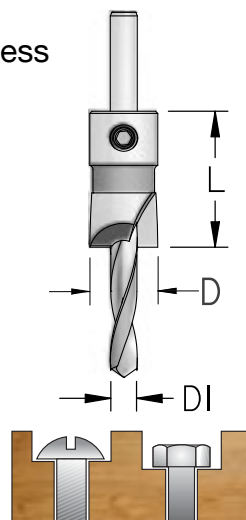

MULTI-DIAMETER TCT COUNTERSINKS & COUNTERBORES

Carbide tipped. Shankless, for assembling on drills.

One tool fits over drills of different sizes, for a quick and easy change on the job. Rather than have a set of tools that may not be the size you need, you could replace them with one adjustable tool.

Note: Counterbore and Countersink Dia. (D) depends on drill Dia. (D1)

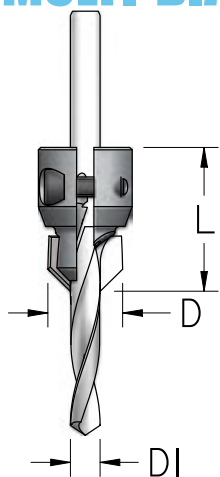

ACM

Multi-Diameter Countersink

Slow Spiral HSS drill included.

Tool No.	D1	D	L
ACM3070D	3-7.2	12-16	29
ACM6010D	6-10	15.5-19.5	34

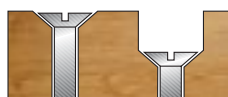

AC4M

Multi-Diameter Counterbore

Slow Spiral HSS drill included.

Tool No.	D1	D	L
AC4M370D	3-7.2	11.5-15.5	28
AC4M610D	6-10	21-25	33

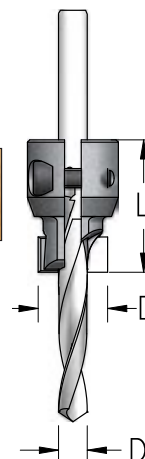

ASO...S

Carbide Tipped Countersinks

HSS drill included. Quick-Change 1/4" (6.3mm) HEX shank.

Tool No.	D1	D	L
AS02004S	2	9.5	54
AS02404S	2.4	9.5	54
AS02504S	2.5	9.5	54
AS02804S	2.8	9.5	54
AS03004S	3.0	9.5	54
AS03204S	3.2	9.5	54
AS03504S	3.5	9.5	54
AS03604S	3.6	12.7	54
AS04004S	4	9.5	54
AS04804S	4.8	12.7	70
AS05004S	5	12.7	70
AS06004S	6	12.7	70
AS06014S	6	15	70

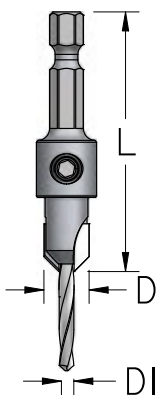

AF

Carbide Tipped Countersinks

Compatible with Festool® CENTROTEC® system
Slow Spiral HSS drill included

Tool No.	D1	D	L
AF02404D	2.4	9.5	74
AF02804D	2.8	9.5	74
AF03204D	3.2	9.5	74
AF03604D	3.6	9.5	74
AF04004D	4.0	9.5	74
AF04404D	4.4	12.0	77
AF05004D	5.0	12.7	77

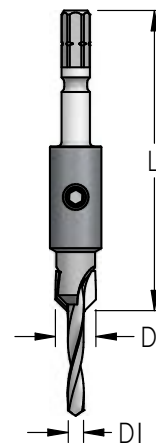

ASO...T

TCT Countersink with Taper Point Drill

Quick-Change 1/4" (6.3mm) HEX shank.

Tool No.	D1	D	L
AS02404T	2.4	9.5	54
AS03204T	3.2	9.5	54
AS03604T	3.6	12.7	54
AS04004T	4	9.5	54
AS04804T	4.8	12.7	70

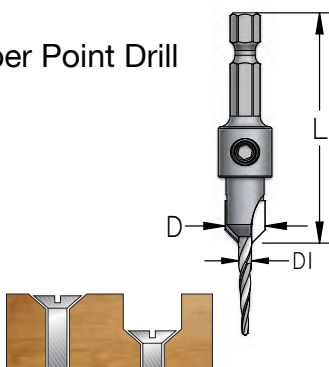

AS4...D

Carbide Tipped Counterbore

Slow Spiral HSS drill included.
Quick-Change 1/4" (6.3mm) HEX shank.

Tool No.	D1	D	L
AS44004D	4	9.5	55
AS44804D	4.8	9.5	55
AS44814D	4.8	12.7	70
AS45014D	5	14	70
AS46014D	6	15	70
AS46304D	6.3	12.7	70

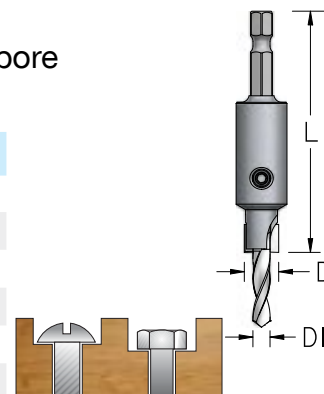

3 STEPS DRILL BITS

For Connecting Screws (Confirmat, Directa etc.).

Performs 3 tasks in one operation:

Pilot hole, Clearance hole and Countersink.

ACD

3 Steps Drill for laminated chipboard

Countersink *DHN treated. Slow Spiral HSS drill included. Round shank.

Tool No.	D1	D2	D	B	L	d
ACD0507D	3.5	5	8	15	53	10
ACD0657D	4.4	6.5	9.6	9.5	50	10
ACD0707KD	5	7	10	10	50	10
ACD0707D	5	7	10	19	59	10

*DHN - Advanced surface treatment for extended life

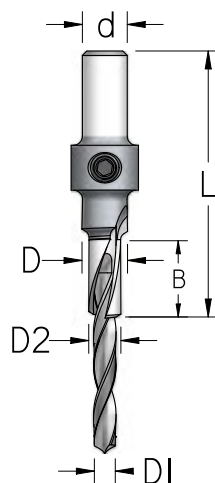
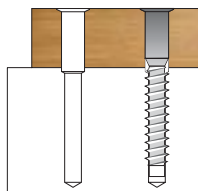

ACD

3 Steps Drill for MDF and other materials

HS Shankless countersink.
Stepped HSS drill included.
Replacement drill: DR50070

Tool No.	D1	D2	D	B	L
ACD0700D	5	7	10	5-25	30

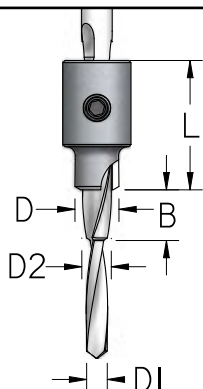

ASD

3 Steps Drill for laminated chipboard

Countersink *DHN treated.
Slow Spiral HSS drill included.
Quick-Change 1/4" (6.3mm) HEX Shank.

Tool No.	D1	D2	D	B	L
ASD0504D	3.5	5	8	15	60
ASD0704D	5	7	10	19	79

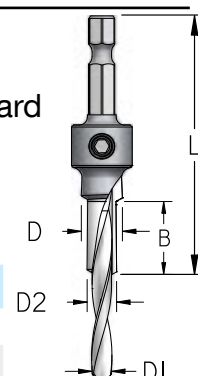



CYLINDER - HINGE BORING BITS

Carbide tipped with a centering point.
Typically used for recessing circular door hinges. For Blind holes and Through holes.

MP

Professional TCT Boring Bits

2 straight cutting edges and 2 spurs.
Round shank.

Tool No.	D	L	d
MP15007	15	85	10
MP19007	19	85	10
MP20007	20	85	10
MP22007	22	85	10
MP25007	25	85	10
MP26007	26	85	10
MP30007	30	85	10
MP35007	35	85	10
MP38007	38	85	10
MP40007	40	85	10
MP45007	45	85	10
MP50007	50	85	10

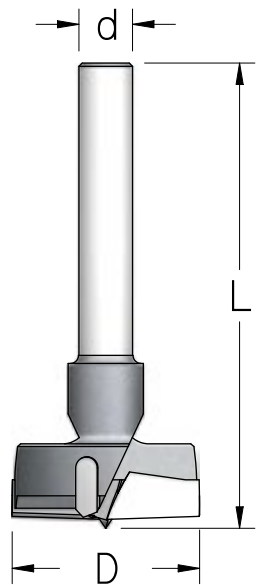

HMP

Economy TCT Boring Bits

2 straight cutting edges. No spurs.
Round shank.
For best results use drill press.

Tool No.	D	L	d
HMP2005	20	57	8
HMP2505	25	57	8
HMP2605	26	57	8
HMP3005	30	57	8
HMP3505	35	57	8

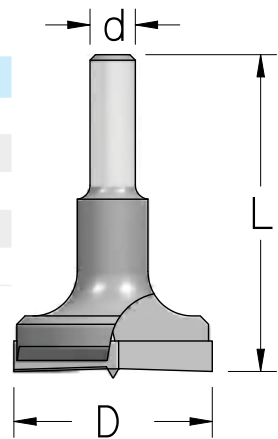

HMPS

Economy TCT Boring Bits

2 straight cutting edges. No spurs.
Quick-Change 1/4" (6.3mm) HEX shank.
For best results use drill press.

Tool No.	D	L
HMPS154	15	55
HMPS204	20	55
HMPS254	25	55
HMPS264	26	55
HMPS304	30	55
HMPS354	35	55

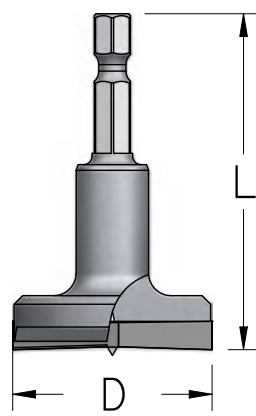

HMPT

TCT Boring Bits

2 straight cutting edges.
Special design for better results.
Quick-Change 1/4" (6.3mm) HEX shank.

Tool No.	D	L
HMPT154	15	58
HMPT264	26	58
HMPT354	35	58
HMPT404	40	58

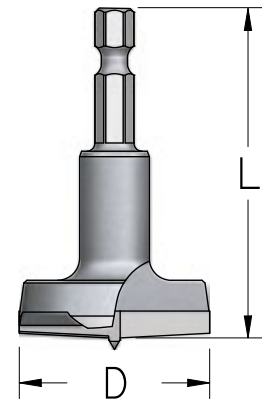

BORING BITS WITH DEPTH-STOP

HMPAL354

Unique adjustable Aluminum depth-stop allows control of depth of blind holes when recessing circular door hinges.

Prevents from damaging the door.
Simple depth control.

Quick-Change 1/4" (6.3mm) HEX Shank.

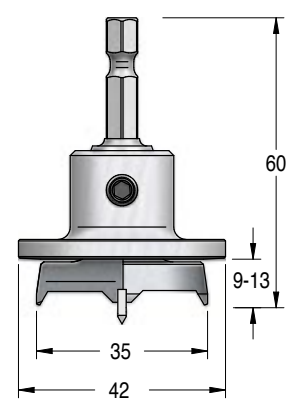



MNS

Plug Cutters - Self Ejecting

Heat-treated and DHN* treated.
One Flute.
For best results use drill press.
Quick-Change 1/4" (6.3mm)
HEX Shank.

Tool No.	D	H max	L
MNS0804	8	19	56
MNS0954	9.5	19	62
MNS1004	10	19	62
MNS1204	12	19	62
MNS1274	12.7	19	62
MNS1504	15	19	63
MNS1604	16	19	63
MNS1904	19	19	63

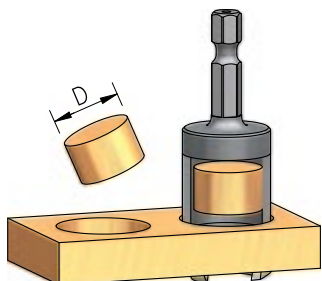
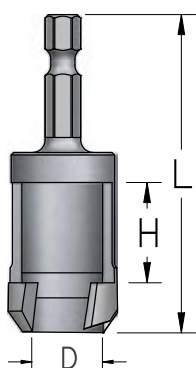

*DHN - Advanced surface treatment for extended life

MN

Plug Cutters - Self Ejecting

Heat-treated and DHN* treated.
One Flute.
For best results use drill press.

Tool No.	D	H max	L	d
MN09505	9.5	19	61	8
MN10005	10	19	61	8
MN12005	12	19	61	8
MN12705	12.7	19	61	8
MN16007	16	19	75	10
MN19007	19	19	75	10
MNL0955	9.5	50	94	8

Extra long design - up to 50mm length of plugs

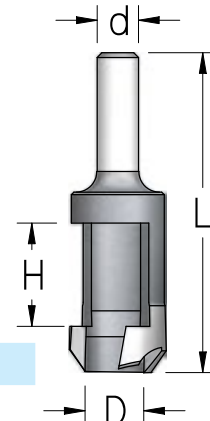

MN

Plug Cutters - Self Ejecting

HS Heat-treated steel.

Tool No.	D	L	d
MN20008	20	140	13
MN25008	25	140	13
MN30008	30	140	13
MN35008	35	140	13

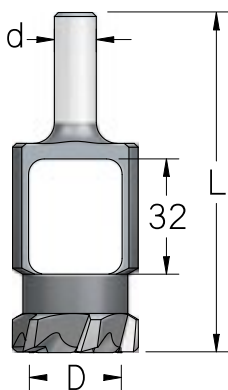

MNK

Tapered TCT Plug Cutters - 2 flutes

A drill press must be used for making tapered plugs up to 16mm long. This ensures a tight fit - no gap around the plug.

This solves the problem of irregular holes as a result of runout in the drill press etc. You just tap a plug into a hole until you meet resistance, then cut off the excess.

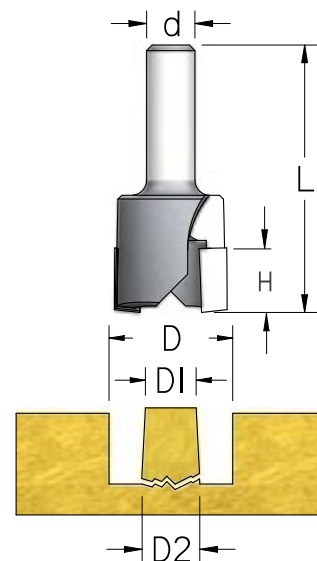

Tool No.	D1	D2	D	H max	L	d
MNK1302	12	13	27.5	16	72	12
MNK1602	15.2	16.2	29.5	16	71	12
MNK2002	18.3	19.5	33	16	71	12

MNT

Carbide Tipped Plug Cutters - 2 flutes

Drill press must be used.
For making plugs up to 16mm Long.

Tool No.	D	H max	L	d
MNT0953	9.5	16	58	6
MNT1003	10	16	58	6
MNT1203	12	16	58	6
MNT1603	16	16	58	6
MNT0952	9.5	16	65	12
MNT1272	12.7	16	65	12
MNT1602	16	16	65	12

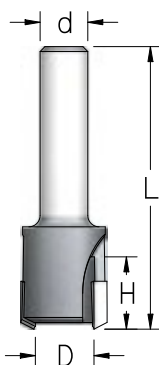

COUNTERSINK & PLUG CUTTER SET

For decorative concealing of screw heads with wooden plugs.
The sets include TCT countersink bit and a matching plug cutter.

After driving the screw, dip the wooden plug in glue. Match up the grain orientation.
Then insert the plug and tap it down with a hammer.
Lastly, trim the plug flush, and use a sanding block to complete the job.

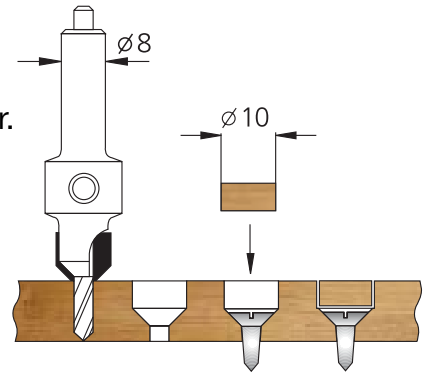

PL

Countersink & Plug Set

Includes TCT countersink bits with different drill diameters and a 10mm plug cutter (MN10005), which fits with all countersinks.
Round shanks 8mm.

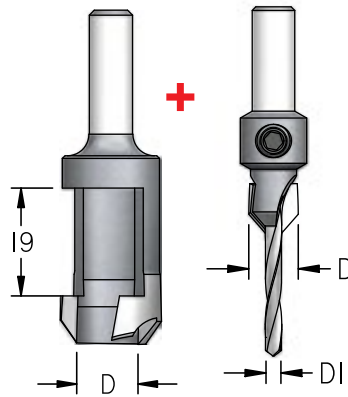

Set No.	Drill Dia. (D1)	Plug Dia (D)
One Countersink + Plug Cutter		
PL10305	3.0	10
PL10325	3.2	10
PL10355	3.5	10
PL10365	3.6	10
PL10405	4.0	10
PL10445	4.4	10
PL10505	5.0	10
4 Countersinks + Plug Cutter		
PL40005	3.0, 3.5, 4.0, 5.0	10
PL41005	3.2, 3.6, 4.0, 4.4	10

PLP

Countersink & Stop Plug Set

Includes one TCT countersink bit with Depth-Stop and a matching plug cutter.
Unique adjustable Low Friction Depth-Stop for clean surface.
Quick-Change 1/4" (6.3mm) HEX Shanks.

Set No.	Drill Dia. (D1)	Plug Dia (D)
One Countersink + Plug Cutter		
PLP1254	2.5	8
PLP1354	3.5	10
PLP1454	4.5	12
PLP1604	6.0	15

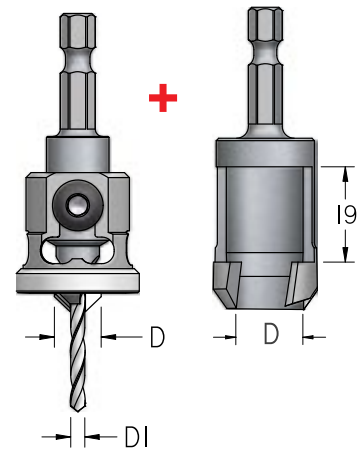

COUNTERSINK COMBINATION SETS

AQPS

Countersink & Stop 3pcs Set

Includes 3 TCT countersinks and one Low friction Depth-Stop which fits all 3 countersinks.
Quick-Change 1/4" (6.3mm) HEX Shanks.



Set No.	Contains
AQPS014	AQ02504S - 2.5mm countersink AQP3004SC - 3.0mm countersink & stop AQ04004SC - 4.0mm countersink

QCS

Countersink & Plug 7pcs Set

Includes 3 TCT countersinks, a matching plug cutter, Quick-Change Chuck and screwdriver bits.
Quick-Change 1/4" (6.3mm) HEX Shanks.



Set No.	Contains
QCS1104	AS02504S - 2.5mm countersink
	AS03004S - 3.0mm countersink
	AS04004S - 4.0mm countersink
	MNS0954 - 9.5mm Plug Cutters
	QCH6306 - Quick-Change Chuck
3 Power screwdriver bits	

TCT GLASS & TILE DRILLS

For use on glass, porcelain, tile and mirrors. When drilling glass, apply lubricant (water or light oil).

HMZ...0

Glass & Tile Drills

Round shank.

Tool No.	D	L
HMZ0300	3	58
HMZ0400	4	59
HMZ0500	5	62
HMZ0600	6	70
HMZ0800	8	81
HMZ1000	10	93
HMZ1200	12	105
HMZ1300	13	105

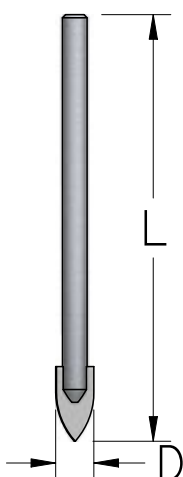

HMZ...4

Glass & Tile Drills

Quick-Change 1/4" (6.3mm) HEX Shanks.

Tool No.	D	L
HMZ0304	3	58
HMZ0404	4	59
HMZ0504	5	62
HMZ0604	6	70
HMZ0704	7	80
HMZ0804	8	81
HMZ1004	10	93
HMZ1204	12	105
HMZ1304	13	105

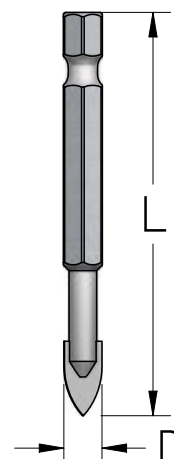

TDS

Drill Adapters

Converts all standard drill bits into Quick-Change tools.

Quick-Change 1/4" (6.3mm) HEX Shanks.

Tool No.	D	L
TDS0200S	2.0	42
TDS0250S	2.5	42
TDS0280S	2.8	42
TDS0300S	3.0	42
TDS0320S	3.2	42
TDS0350S	3.5	42
TDS0360S	3.6	42
TDS0400S	4.0	42
TDS0440S	4.4	42
TDS0480S	4.8	42
TDS0500S	5.0	42
TDS0600S	6.0	51
TDS0630S	6.3	51

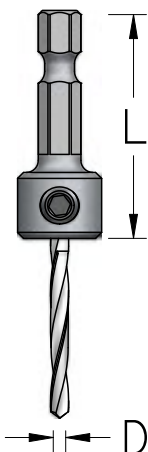

QC

Quick - Change Chuck

For 1/4" (6.3mm) hexagonal shanks.

Converts all standard drill chucks into Quick Change attachment.

Insert this chuck into a power drill chuck and tighten it using the chuck key.

Now you can change tools instantly by just pulling the sleeve.

No chuck key needed anymore!

QCL6306

Professional chuck



QCH6306

DIY chuck



REPLACEMENT DEPTH STOPPERS

TATP

Low Friction Depth Stopper

With replaceable polymer ring.

Tool No.	D1	D	L
TATP130	13	25	25
TATP150	15	28	25

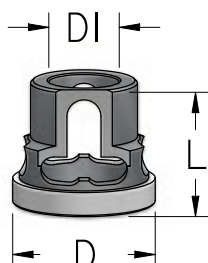

TAB

Non Friction Depth Stopper

Revolving metal body.
Includes a thrust ball bearing.

Tool No.	D1	D	L
TAB1300	13	32	32.5
TAB1500	15	32	32.5

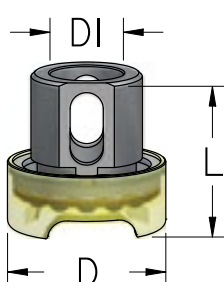

BTAT

Polymer Collar Replacement kit

- 1 Stopper body
- 2 Polymer ring
- 3 Flange

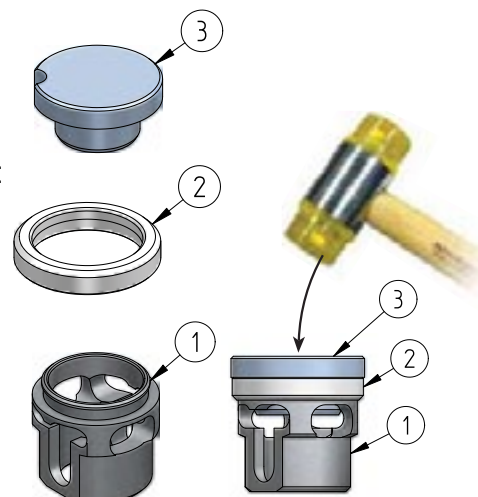

Tool No.	Contains
BTAT0255	Flange plus 5 Polymer rings for TATP130
BTAT0285	Flange plus 5 Polymer rings for TATP150



DR

HSS Drills

DIN 338. M2 Fully ground.

Tool No.	D	L
DR02000	2.0	49
DR02400	2.4	57
DR02500	2.5	57
DR02800	2.8	61
DR03000	3.0	61
DR03200	3.2	65
DR03500	3.5	70
DR03600	3.6	70
DR04000	4.0	75
DR04400	4.4	80
DR04500	4.5	80
DR04800	4.8	86
DR05000	5.0	86
DR05600	5.6	93
DR06000	6.0	93
DR06300	6.3	101
DR07000	7.0	109

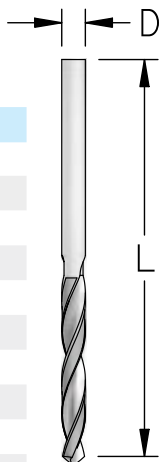

DRK

HSS Short Drills

DIN 1897.
M2 Fully ground.

Tool No.	D	L
DRK0280	2.8	46
DRK0300	3.0	46
DRK0320	3.2	49
DRK0350	3.5	52
DRK0360	3.6	52
DRK0400	4.0	55
DRK0440	4.4	58
DRK0450	4.5	58
DRK0480	4.8	62
DRK0500	5.0	62
DRK0600	6.0	66

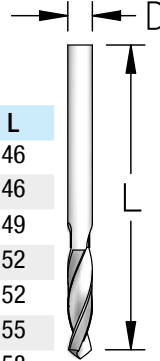

DRT

HSS Taper Point Drills

M2 Fully ground.

Tool No.	D	L
DRT0200	2.0	51
DRT0240	2.4	57
DRT0280	2.8	68
DRT0320	3.2	70
DRT0360	3.6	73
DRT0400	4.0	80
DRT0440	4.4	83
DRT0480	4.8	89
DRT0500	5.0	89
DRT0560	5.6	95
DRT0600	6.0	98
DRT0630	6.3	102

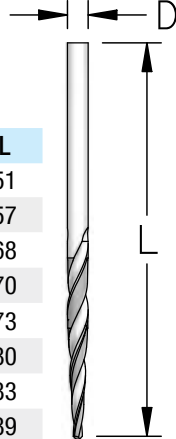

DRS

HSS Slow Spiral Drills

DIN 338. M2 Fully ground.

Tool No.	D	L
DRS0200	2.0	49
DRS0240	2.4	57
DRS0280	2.8	61
DRS0320	3.2	65
DRS0350	3.5	70
DRS0360	3.6	70
DRS0400	4.0	75
DRS0440	4.4	80
DRS0480	4.8	86
DRS0500	5.0	86
DRS0560	5.6	93
DRS0600	6.0	93
DRS0630	6.3	101
DRS0800	8.0	117
DRS0900	9.0	125
DRS0950	9.5	125
DRS1110	11.1	142
DRS1270	12.7	150

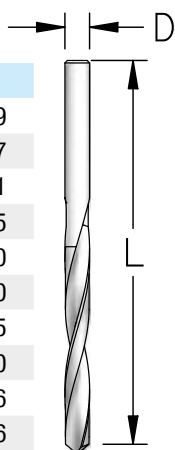

DR

HSS Stepped Drills

M2 Fully ground.

Unique solution for one drilling operation of:
Pilot hole + Clearance hole.

Tool No.	DI	D	L	LI
DR24036	2.4	3.6	70	16
DR28040	2.8	4.0	75	19
DR32044	3.2	4.4	80	22
DR35050	3.5	5.0	86	25
DR50070	5.0	7.1	109	25

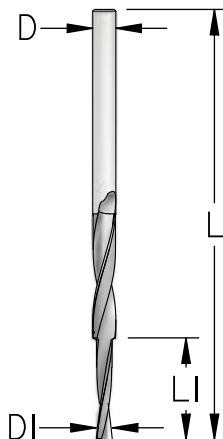

TATM

Adjustable Drill Depth-Stops

Can be clamped onto any drill, either on the flute or on the shank.

An innovative and universal solution to the problem of drilling holes to an accurate depth.

Special design to minimize any marks on the surface being drilled.

Tool No.	D	L
TATM3070	3-7	14
TATM6100	6-10	20

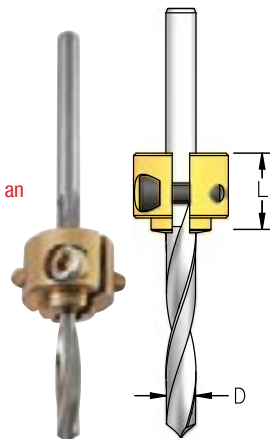

INDUSTRIAL DRILLING

WPW offers Dowel Drills, countersinks, professional hinge boring bits and accessories for Multi Drilling Machines, CNC machines and other machines with "Combi" system chuck.





DDB

Dowel Drills for Blind Holes

Carbide Tipped

Fits 10 mm combi chucks right hand and left hand rotation.

Tool No.		D	L	L1	d
Right	Left	mm	mm	mm	mm
DDB04577	DDB04577L	4	57.5	27	10x27
DDB05577	DDB05577L	5	57.5	27	10x27
DDB06577	DDB06577L	6	57.5	27	10x27
DDB07577	DDB07577L	7	57.5	27	10x27
DDB08577	DDB08577L	8	57.5	27	10x27
DDB10577	DDB10577L	10	57.5	27	10x27
DDB12577	DDB12577L	12	57.5	27	10x27
DDB04707	DDB04707L	4	70	35	10x30
DDB05707	DDB05707L	5	70	35	10x30
DDB06707	DDB06707L	6	70	35	10x30
DDB07707	DDB07707L	7	70	35	10x30
DDB08707	DDB08707L	8	70	35	10x30
DDB10707	DDB10707L	10	70	35	10x30
DDB12707	DDB12707L	12	70	35	10x30

Tool No.		D	L	L1	d
Right	Left	mm	mm	mm	mm
DDB05777	DDB05777L	5	77	44	10x30
DDB06777	DDB06777L	6	77	44	10x30
DDB07777	DDB07777L	7	77	44	10x30
DDB08777	DDB08777L	8	77	44	10x30
DDB10777	DDB10777L	10	77	44	10x30
DDB12777	DDB12777L	12	77	44	10x30

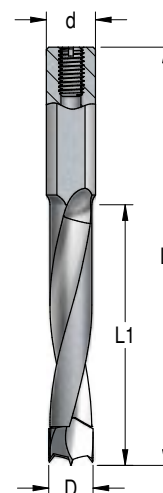

DDT

Through Hole Drills

Carbide Tipped

Fits 10 mm combi chucks right hand and left hand rotation.

Tool No.		D	L	L1	d
Right	Left	mm	mm	mm	mm
DDT05577	DDT05577L	5	57.5	25	10x25
DDT06577	DDT06577L	6	57.5	25	10x25
DDT07577	DDT07577L	7	57.5	25	10x25
DDT08577	DDT08577L	8	57.5	25	10x25
DDT05707	DDT05707L	5	70	40	10x25
DDT06707	DDT06707L	6	70	40	10x25
DDT07707	DDT07707L	7	70	40	10x25
DDT08707	DDT08707L	8	70	40	10x25
DDT10707	DDT10707L	10	70	40	10x25
DDT12707	DDT12707L	12	70	40	10x25

Tool No.		D	L	L1	d
Right	Left	mm	mm	mm	mm
DDT05777	DDT05777L	5	77	45	10x25
DDT06777	DDT06777L	6	77	45	10x25
DDT07777	DDT07777L	7	77	45	10x25
DDT08777	DDT08777L	8	77	45	10x25
DDT10777	DDT10777L	10	77	45	10x25

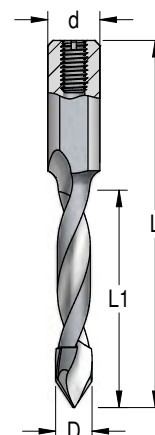



MPK

Cylinder-Hinge Boring Bits - Combi System

Carbide tipped with a centering point, 2 straight cutting edges and 2 nicking teeth.
Fits 10 mm combi chucks right hand and left hand rotation.

Tool No.		D	L	d
Right	Left	mm	mm	mm
MPK1507	MPK1507L	15	56.5	10x26
MPK1607	MPK1607L	16	56.5	10x26
MPK1807	MPK1807L	18	56.5	10x26
MPK2007	MPK2007L	20	56.5	10x26
MPK2207	MPK2207L	22	56.5	10x26
MPK2507	MPK2507L	25	56.5	10x26
MPK2607	MPK2607L	26	56.5	10x26
MPK3007	MPK3007L	30	56.5	10x26
MPK3507	MPK3507L	35	56.5	10x26
MPK3807	MPK3807L	38	56.5	10x26
MPK4007	MPK4007L	40	56.5	10x26

Tool No.		D	L	d
Right	Left	mm	mm	mm
MPK1517	MPK1517L	15	69	10x26
MPK2017	MPK2017L	20	69	10x26
MPK2517	MPK2517L	25	69	10x26
MPK3017	MPK3017L	30	69	10x26
MPK3517	MPK3517L	35	69	10x26

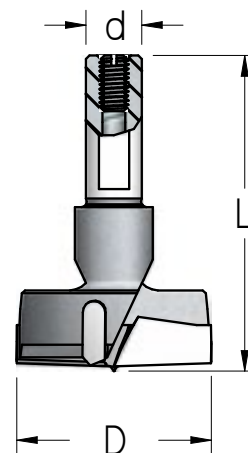

Combi Chuck Accessories

TK

Shank Drill Bushings

Tool No.	D	L	d
	mm	mm	mm
TK10020	2.0	23	10
TK10025	2.5	23	10
TK10030	3.0	23	10
TK10032	3.17 (1/8")	23	10
TK10035	3.5	23	10
TK10040	4.0	23	10
TK10045	4.5	23	10
TK10050	5.0	23	10
TK10055	5.5	23	10
TK10060	6.0	23	10
TK10070	7.0	23	10
TK10080	8.0	23	10

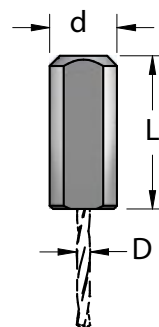

TA

Combi Chuck Adapters for Drills

Drill not included.

Tool No.	D	L	d
	mm	mm	mm
TA10020	2.0	38	10x22
TA10025	2.5	38	10x22
TA10030	3.0	38	10x22
TA10032	3.17 (1/8")	38	10x22
TA10035	3.5	38	10x22
TA10040	4.0	38	10x22
TA10050	5.0	38	10x22
TA10063	6.35 (1/4")	38	10x22

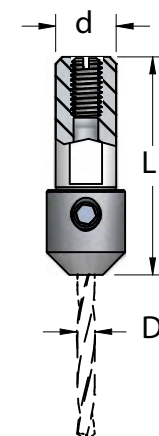

Locking screw - BR40050 (M4 x 5), Allen key - KEY5/64 (2mm)

TA

Adapters for "Combi" System drills

For CNC and Router machines

Allows using combi system drills, such as dowel drills, boring bits etc. in wide range of applications.

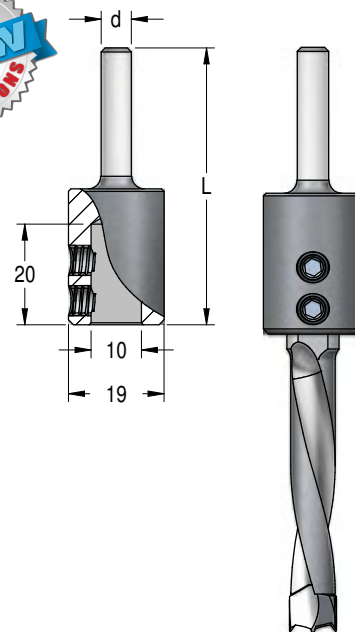

Tool No.	d mm	L mm
TA10003	6	55
TA10004	6.35 (1/4")	55
TA10005	8	57
TA10007	10	55
TA10002	12	62
TA10008	12.7 (1/2")	62

2 Locking screws - BR60050 (M6 x 5), Allen key - KEY03.0 (3mm)

TM

Boring Machine Chucks - Combi System

For 10mm Shank Boring Bits

Right hand and left hand rotation.

Tool No.		d	D mm	α degrees	B mm	L mm	For Machines
Right	Left						
TM08101R	TM08101L	M8	-	-	15	40	NOTTMEYER
TM10103R	TM10103L	M10	-	-	15	40	AYEN, TORWEGGE, HOLZMA...
TM08104R	TM08104L	M8	9	-	16	41	NOTTMEYER
TM08114R	TM08114L	M8	9	-	16	52	NOTTMEYER
TM10105R	TM10105L	M10	11	-	16	41	HOLZMA, S.C.M.I., MORBIDELLI, BIESSE, TORWEGGE...
TM08106R	TM08106L	M10	-	20°48'	12	51	BILEK
TM10102R	TM10102L	M10	-	30	12	47	BILEK, VITAP, BUSSELATO, OMPEX...
TM10107R	TM10107L	M10	-	-	-	46	SCHEER

2 Locking screws - BR50050 (M5 x 5), Allen key - KEY02.5 (2.5mm)

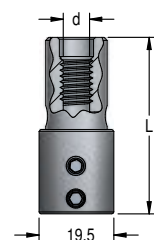
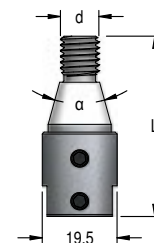
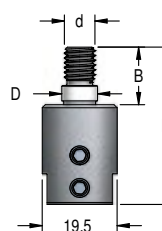
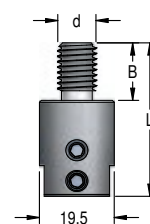

AC3

Countersinks for Dowel Drills

Carbide Tipped

Right hand and left hand rotation.

Drills not included.

Tool No.		D1	D	L
Right	Left	mm	mm	mm

Designed to be assembled on the drill flute
For individual drill Diameters

AC3040R	AC3040L	4	15.5	18
AC3050R	AC3050L	5	16	18
AC3060R	AC3060L	6	16	18
AC3070R	AC3070L	7	16	18
AC3080R	AC3080L	8	18	18
AC3090R	AC3090L	9	18	18
AC3100R	AC3100L	10	20	18
AC3120R	AC3120L	12	20	18

Designed to be assembled on the drill 10mm shank
Fits a range of drill Diameters

AC31112R	AC31112L	11-12	22	17
AC35101R*	AC35101L*	5-10	15.5	19
AC3510R	AC3510L	5-10	20	19

Locking screw - BR60060 (M6 x 6), Allen key - KEY03.0 (3mm)

*Locking screw - BR40040 (M4 x 4), Allen key - KEY5/64 (2mm)

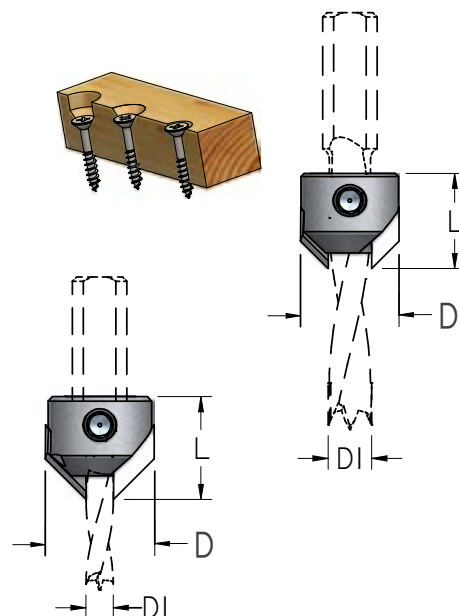

ACK

Countersinks - Combi System

Carbide Tipped.

HSS drill included.

Tool No.	D1	D	L	d
	mm	mm	mm	mm
ACK4007D	4.0	12.7	60	10x30
ACK5007D	5.0	12.7	60	10x30

Locking screw - BR60050 (M6 x 5), Allen key - KEY03.0 (3mm)

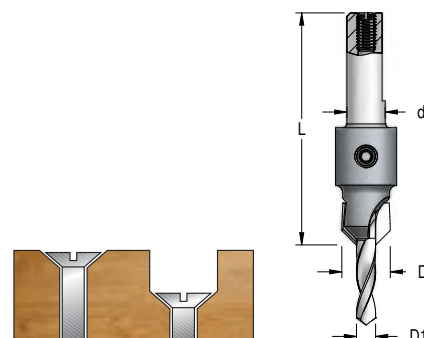

ACF

Face Frame Counterbore

Carbide tipped.

HSS drill included.

Tool No.	D1	D	B	L	d
	mm	mm	mm	mm	mm
ACFS950S	3.45	9.5	9	104	9
ACF2950S	3.45	9.5	9	152	9

Replaceable "Fish tail" drill - DR03450

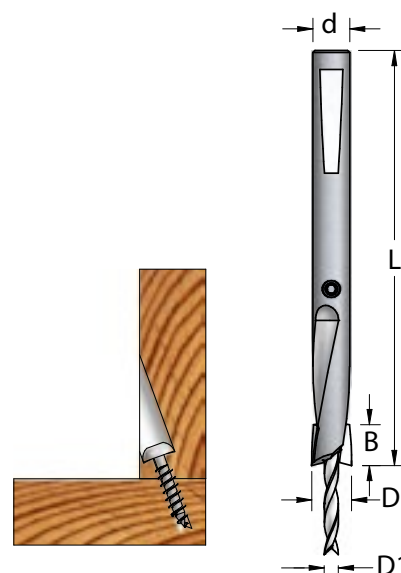

DIAMOND ROUTER BITS

PCD and Diamond Grit Coated router bits.

WPW PCD bits last 30- 50 times longer than Carbide tools and are very efficient in cutting abrasive materials including composites, particleboard, MDF and hardwoods.

Diamond Grit Coated Router Bits are designed for cutting Fiberglass, Carbon Fiber and other Composite materials.

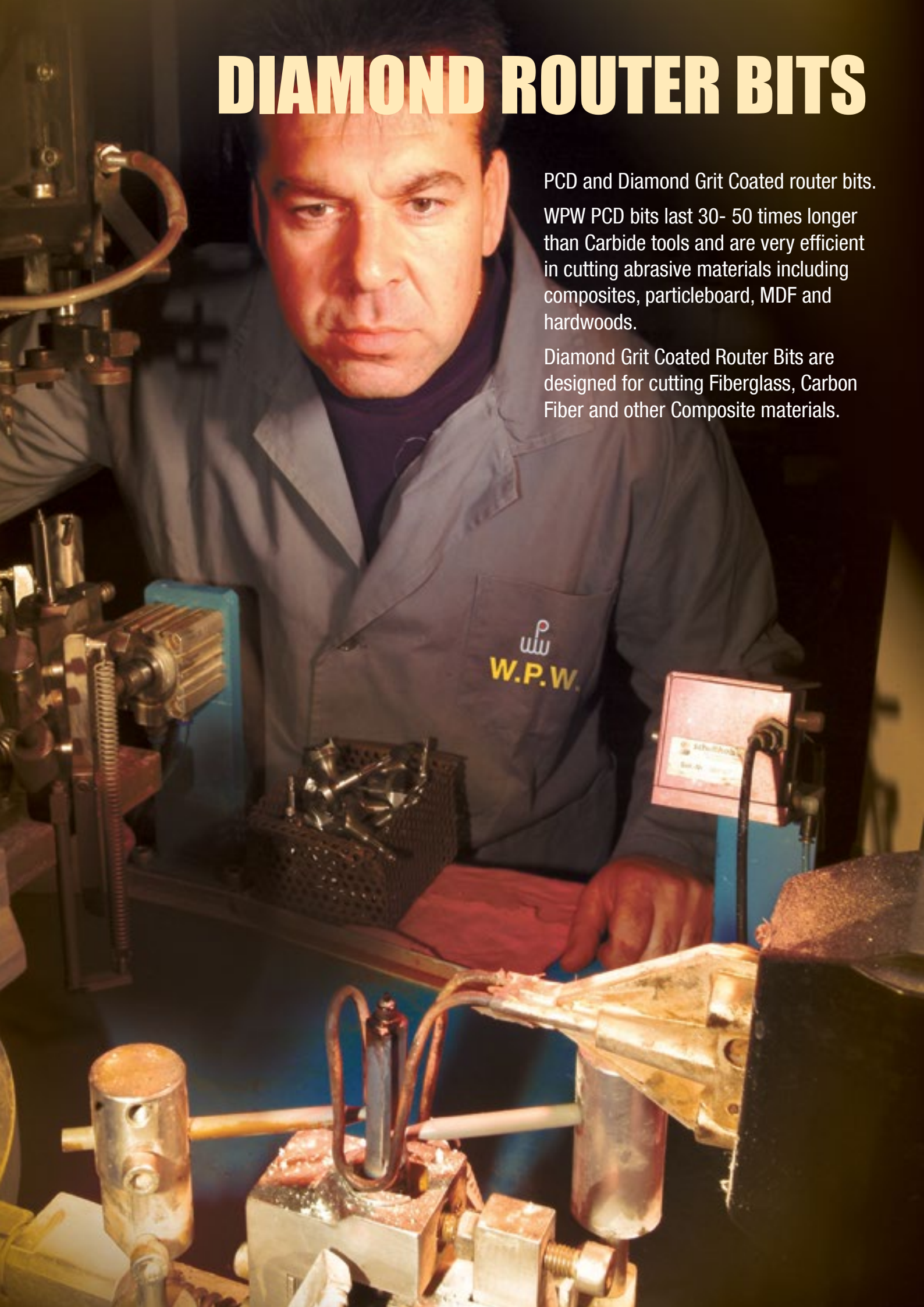

Diamond Tipped PCD Router Bits

Polycrystalline Diamond (PCD) is an extremely hard cutting material. These Diamond tipped tools last 30- 50 times longer than Carbide tipped tools.

They are very efficient in cutting a wide variety of tough abrasive materials including composites, particleboard, MDF (either raw or laminated), HPL, veneers and hardwoods.

The common application is pre-cutting and sizing panels of abrasive materials in Point to Point CNC machines.

Designed for use on CNC machines, these tools have a much longer cutting life, eliminating the need to change tools often, saving setup time and minimizing the handling of dull tools.

The Up / Down Shear design of the cutters, often referred to as "Compression" Bits, results in a good surface finish on double sided laminated materials.

SR1

Straight Plunge PCD Bits. Up/Down

1+1 Flutes. Carbide Plunging tip.

Tool No.		D	B	L
d=12mm	d=1/2"	d=16mm	d=20mm	
	SR140958	9.5	25	75
SR141202		12	25	75
SR151202		12	34	85
	SR141278	12.7	25	75
	SR151278	12.7	34	85
	SR151601	16	35	85
	SR18200E	20	52	112

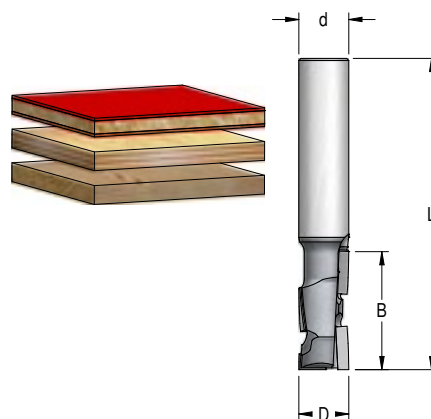

SR2

Straight Plunge PCD Bits. Up/Down

2+2 Flutes. For high production.

Tool No.		D	B	L
d=16mm	d=20mm	mm	mm	mm
SR251601		16	34	94
	SR25200E	20	34	94

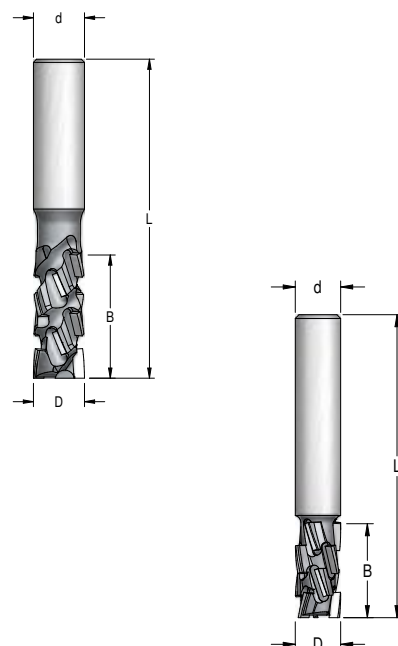

SR3

Straight Plunge PCD Bits. Up/Down

3 + 3 Flutes. For best results in nesting.

Tool No.	D	B	L
d=12mm	mm	mm	mm
SR341202	12	24	75

PD

Straight Plunge PCD Bits.

Single Flute. Designed for Routing Solid wood panels.

Tool No.		D	B	L
d=6mm	d=8mm	mm	mm	mm
PD130603		6	20	70
	PD130805	8	20	70

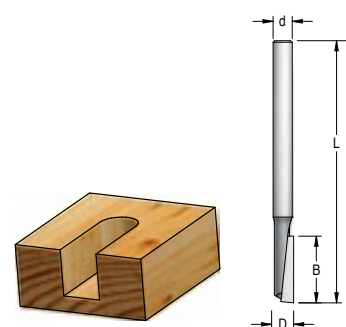

FD

Flush Trim PCD Bit.

2 Flutes. For super abrasive laminates, HPL, veneers etc.

Tool No.		D	B	L
d=6mm	d=1/4"	mm	mm	mm
FD221273	FD221274	12.7	11.1	58

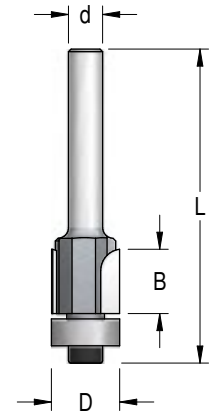
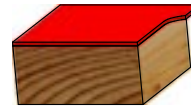

Diamond Grit Coated Router Bits

For cutting Fiberglass, Carbon Fiber and other Composite materials

PG

Straight "Down-Cut" Bits.

With spiral cooling slots.

Tool No.		D	B	L	Diamond Grit size
d=6mm	d=1/4"	mm	mm	mm	
PG35063/501	PG35064/501	6.3	32	76	D501
PG36063/501	PG36064/501	6.3	38	76	D501
	PG36096/501	9.5	38	76	D501

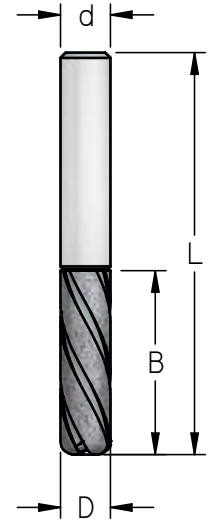
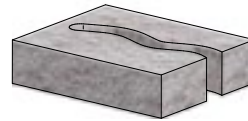

FG

Flush Trim Bits

With straight cooling slots.

Tool No.		D	B	L	Diamond Grit size	Ball Bearing
d=6mm	d=1/4"	mm	mm	mm		
FG30633/427	FG30634/427	6.3	19	59	D427	B063032
FG40633/427	FG40634/427	6.3	25	64	D427	B063032
FG40953/427	FG40954/427	9.5	25	67	D427	B095048

Tool No.		D	B	L	Diamond Grit size	Ball Bearing
d=12mm	d=1/2"	mm	mm	mm		
FG41272/427	FG41278/427	12.7	25	83	D427	B127048
FG71282/427	FG71288/427	12.7	45	109	D427	B127048 x 2*
FG81282/427	FG81288/427	12.7	51	111	D427	B127048 x 2*

*Double Bearing for added stability

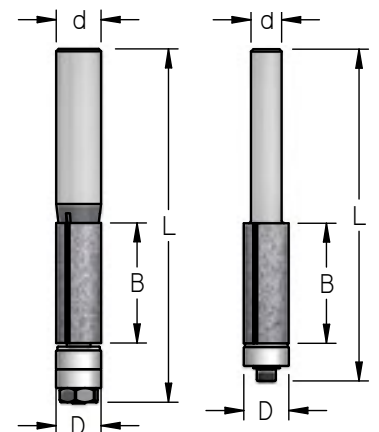
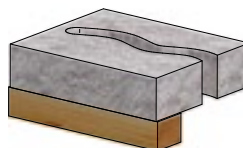

PROFFESIONAL ROUTER BITS

With many creative ideas, this section presents a very comprehensive range of industrial quality Router Bits – Tungsten carbide tipped, solid carbide and replaceable carbide.

This range is the best choice when the quality of the cut and long tool life are the primary factors. It should satisfy the most demanding applications in manufacturing and in the woodworking trade.

Tools with harder WPW K-Carbide grade have up to 200 % longer lifetime than tools with standard carbide. They are excellent for cutting MDF and other hard materials.





Solid Carbide Spiral CNC Bits

For higher feed rates and longer tool life in CNC machines.

These tools cut with less energy and less vibration than Carbide Tipped straight router bits, leaving a perfect and clean finish on hardwood, softwood and man made materials.

Upcut geometry pulls the chips from the working area, allowing deep grooving and higher feed rates.

Downcut geometry directs chips towards the work piece and results smoother cut and cleaner edge of laminated boards.

The combination of Upcut and Downcut design, also called: "Compression", is ideal for perfect cutting with clean edges of double-sided laminated materials.

SCU, SCS

Double flute Spiral Bits - Upcut and Downcut

Upcut Tool No.	Downcut Tool No.	d = D mm	B mm	L mm
SCU22040h	SCS22040h	4	12	55
SCU230603	SCS230603	6	20	60
SCU240805	SCS240805	8	25	60
SCU251007	SCS251007	10	32	70
SCU271202	SCS271202	12	42	90

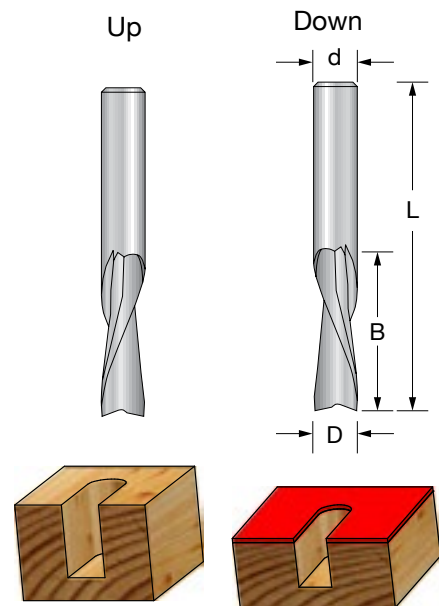

SCC2

"Compression" Bits - 2 Flutes

Tool No.	d = D mm	B mm	B1 mm	L mm
SCC240805	8	25	7	70
SCC251007	10	32	8	80
SCC251202	12	32	8	80

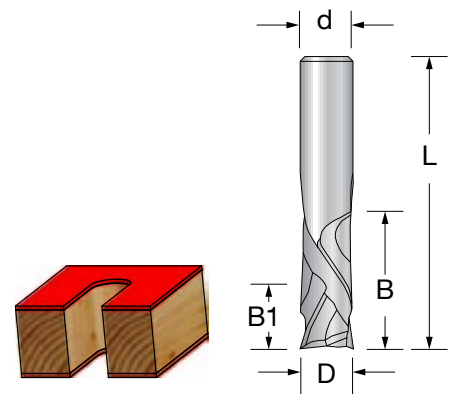

SCC3

Nesting "Compression" Bits - 3 flutes

The 3 flutes design allows higher feed rates than in any other cutting tool.

The common application is "nesting", which is the process of laying out cutting patterns to minimize the raw material waste.

Tool No.	d = D mm	B mm	B1 mm	L mm
SCC341007	10	25	7	70
SCC351202	12	32	9	80
SCC351278	12.7 (½")	32	9	76

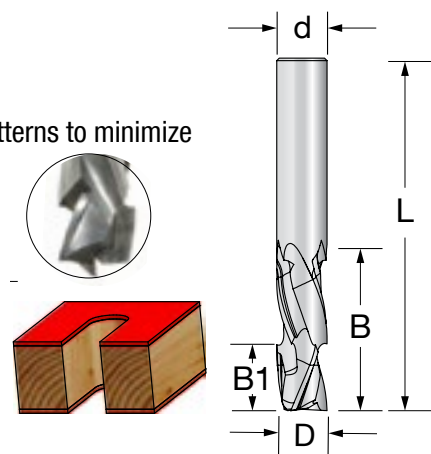

STRAIGHT PLUNGE-CUTTING BITS-2 FLUTES, CARBIDE TIPPED

P2

Straight Plunge - Mini Bits

1/8" Shank for CNC Routers, Dremel and equivalent rotary machines

Solid Carbide Cutting Edge

Tool No. d=1/8" (3.17mm)	D mm	B mm	L mm
P21016i	1.6	4.8	38
P21024i	2.4	8	38
P21032i	3.2	11	38
P21048i	4.8	11	38

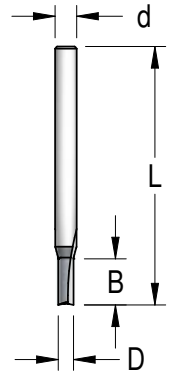
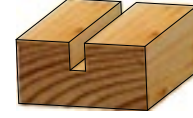

P2

Straight Bits with Solid Carbide Cutting Edge.

Tool No.		D	B	L	
d=6mm	d=1/4"	mm	mm	mm	
P210153	P210154	1.5	5	44	
P210163	P210164	1.6	5	44	
P210203	P210204	P210205	2.0	5	44
P210253	P210254		2.5	8	51
		P210275	2.7	8	51
P210303	P210304	P210305	3.0	11	51
P200323	P200324		3.2	8	47
P210323	P210324		3.2	11	51
P210353	P210354		3.5	11	51
P210403	P210404	P210405	4.0	11	51
		P220405	4.0	12	51
P210483	P210484		4.8	11	51
P210503	P210504	P210505	5.0	11	51
		P220505	5.0	16	57
P290503	P290504		5.0	11	60
P220503	P220504		5.0	16	57
P23S603	P23S604		6.0	19	57
		P24S0605	6.0	25	69

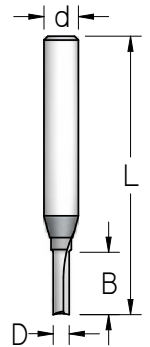
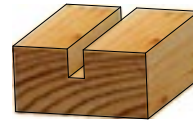

P2

Straight Bits

Tool No.			D	B	L	Tool No.			D	B	L
d=6mm	d=1/4"	d=8mm	mm	mm	mm	d=6mm	d=1/4"	d=8mm	mm	mm	mm
P230603	P230604	P230605	6.0	19	51	P231203	P231204	P231205	12.0	19	51
P240603	P240604	P240605 /K	6.0	25	57	P241203	P241204	P241205 /K	12.0	25	57
P220633	P220634		6.3	13	51			P251205 /K	12.0	32	63
P230633	P230634		6.3	19	51			P271205 /K	12.0	42	73
P240633	P240634		6.3	25	57	P231273	P231274		12.7	19	51
P290633	P290634		6.3	25	73	P241273	P241274		12.7	25	57
P230703	P230704	P230705	7.0	19	51	P251273	P251274	P251275	12.7	32	63
P240703	P240704		7.0	25	57	P231403	P231404	P231405	14.0	19	51
P230803	P230804	P230805	8.0	19	51	P231433	P231434		14.3	19	51
P240803	P240804	P240805 /K	8.0	25	57	P231503	P231504	P231505	15.0	19	51
P230953	P230954		9.5	19	51	P231603	P231604	P231605	16.0	19	51
P240953	P240954		9.5	25	57	P241603	P241604	P241605	16.0	25	57
P250953	P250954		9.5	32	63	P231703	P231704		17.0	19	51
P231003	P231004	P231005	10.0	19	51	P231803	P231804	P231805	18.0	19	51
P241003	P241004	P241005 /K	10.0	25	57	P231903	P231904	P231905	19.0	19	51
P251003	P251004	P251005 /K	10.0	32	63	P232003	P232004	P232005	20.0	19	51
P231103	P231104		11.0	19	51			P232205	22.0	19	51
P241103	P241104		11.0	25	57	P232503	P232504	P232505	25.0	19	51

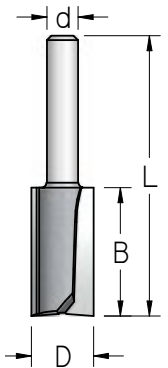

K- Can be ordered with Harder K-Carbide. While ordering, just add the letter "K" to the Tool No.

P2

Straight Bits with Solid Carbide Cutting Edge.

Tool No.		D	B	L
d=12mm	d=1/2"	mm	mm	mm
P210402	P210408	4.0	11	63
P210502	P210508	5.0	11	63
P23S602	P23S608	6.0	19	63
P24S602	P24S608	6.0	25	76
P24S632	P24S638	6.3	25	76

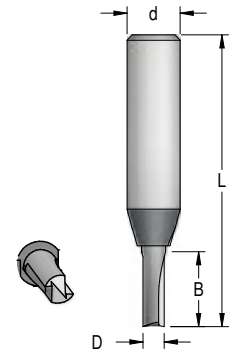
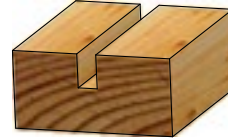

P2

Straight Bits

Tool No.		D	B	L
d=12mm	d=1/2"	mm	mm	mm
P230602 /K	P230608 /K	6.0	19	63
P230632 /K	P230638 /K	6.3	19	63
P240632	P240638	6.3	25	70
P230802	P230808	8.0	19	63
P240802 /K	P240808 /K	8.0	25	70
P230952	P230958	9.5	19	63
P240952 /K	P240958 /K	9.5	25	70
P250952	P250958	9.5	32	76
P241002 /K	P241008 /K	10.0	25	70
P251002 /K	P251008 /K	10.0	32	76
P241102	P241108	11.0	25	70
P251102 /K	P251108 /K	11.0	32	76
P241202 /K	P241208 /K	12.0	25	70
P251202 /K	P251208 /K	12.0	32	73
P261202 /K	P261208 /K	12.0	38	80
P281202 /K	P281208 /K	12.0	51	108
P201202	P201208	12.0	75	133
P241272 /K	P241278 /K	12.7	25	67
P251272 /K	P251278 /K	12.7	32	73
P261272 /K	P261278 /K	12.7	38	80
P271272 /K	P271278 /K	12.7	38	108
P281272 /K	P281278 /K	12.7	51	108
P291272	P291278	12.7	63	114
P201272 /K	P201278 /K	12.7	75	133
P261302	P261308	13.0	38	80
P251352 /K	P251358 /K	13.5	32	73
P241402	P241408	14.0	25	70
P251402 /K	P251408 /K	14.0	32	73

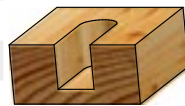
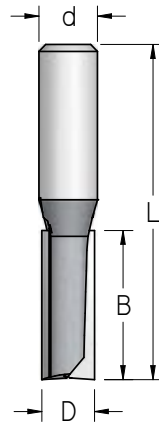

Tool No.		D	B	L
d=12mm	d=1/2"	mm	mm	mm
P241432	P241438	14.3	25	70
P251432	P251438	14.3	32	73
P241602	P241608	16.0	25	70
P251602 /K	P251608 /K	16.0	32	73
P261602 /K	P261608 /K	16.0	38	80
P281602 /K	P281608 /K	16.0	51	96
P241702	P241708	17.0	25	70
P251762	P251768	17.5	32	73
P241802	P241808	18.0	25	70
P251802 /K	P251808 /K	18.0	32	73
P241902 /K	P241908 /K	19.0	25	70
P251902	P251908	19.0	32	73
P261902 /K	P261908 /K	19.0	38	80
P281902 /K	P281908 /K	19.0	51	96
P252002 /K	P252008 /K	20.0	32	73
P282002	P282008	20.0	51	96
P252062	P252068	20.6	32	73
P252202	P252208	22.0	32	73
P252222 /K	P252228 /K	22.2	32	73
P252502	P252508	25.0	32	73
P242542	P242548	25.4	25	70
P252542 /K	P252548 /K	25.4	32	73
P253002	P253008	30.0	32	73
P253202 /K	P253208 /K	31.8	32	73
P253502	P253508	35.0	32	73
P253802 /K	P253808 /K	38.1	32	73
P254502	P254508	45.0	32	73
P255102	P255108	51.0	32	73

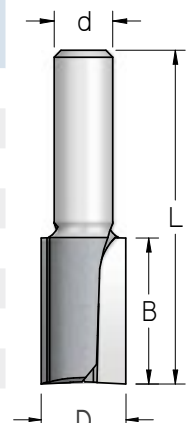

K- Can be ordered with Harder K-Carbide. While ordering, just add the letter "K" to the Tool No.

P2...XK

Straight CNC Long Bits

Extended shank and hard K-Carbide grade, makes these tools perfect for CNC routing and router table jobs. Excellent for cutting MDF and other hard material. Up to 200 % longer lifetime when cutting abrasive materials.
2 Flutes

	Tool No.			D	B	L
	d=8mm	d=12mm	d=1/2"			
P241805XK				18.0	25	70
P242005XK				20.0	25	70
P242205XK				22.0	25	70
P242405XK				24.0	25	70
P242505XK				25.0	25	70
	P261802XK	P261808XK		18.0	38	90
	P262002XK	P262008XK		20.0	38	90
	P262202XK	P262208XK		22.0	38	90
	P262402XK	P262408XK		24.0	38	90
	P262502XK	P262508XK		25.0	38	90

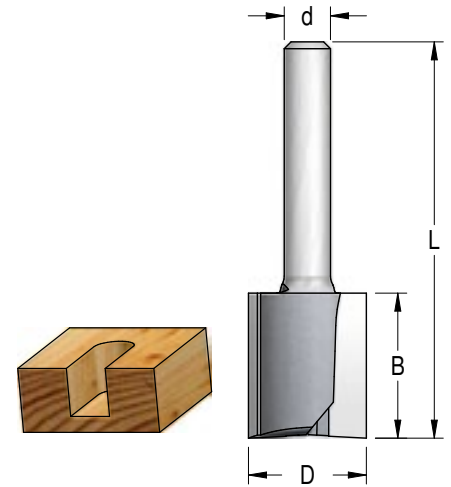

NEED AN EVEN LONGER TOOL?

Check our TX – Shank Extension Adapters, Pg 79.

These adapters, allow deeper reach for wide range of applications. Very useful when the bit is too short for the job.



PT

Straight Bits - Carbide Center Tip with hard K-Carbide grade.

For faster and easier plunging. Longer tool life when plunging hard materials.

	Tool No.			D	B	L
	d=8mm	d=12mm	d=1/2"			
PT30805				8.0	19	51
PT31005				10.0	19	51
PT41205				12.0	25	57
PT41605				16.0	25	57
PT41805				18.0	25	57
	PT30802	PT30808		8.0	19	63
	PT31002	PT31008		10.0	19	63
	PT41202	PT41208		12.0	25	67
	PT81202	PT81208		12.0	51	108
	PT41402	PT41408		14.0	25	67
	PT41602	PT41608		16.0	25	67
	PT81602	PT81608		16.0	51	95
	PT41802	PT41808		18.0	25	67
	PT42002	PT42008		20.0	25	67
	PT42542	PT42548		25.4	25	67

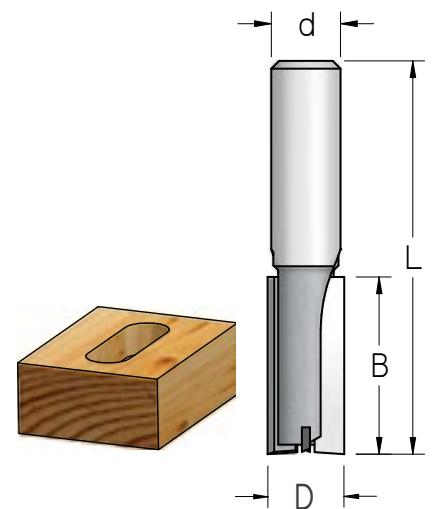

Straight Plunge Cutting Bits - Single Flute

For faster feed rates and maximum stock removal.

P1

Single Flute with Solid Carbide cutting edge.

Tool No.		D	B	L	
d=6mm	d=1/4"	d=8mm	mm	mm	
P110103	P110104		1.0	3	43
P110153	P110154		1.5	5	43
P110163	P110164	P110165	1.6	5	43
P110183	P110184		1.8	5	43
P110203	P110204	P110205	2.0	5	43

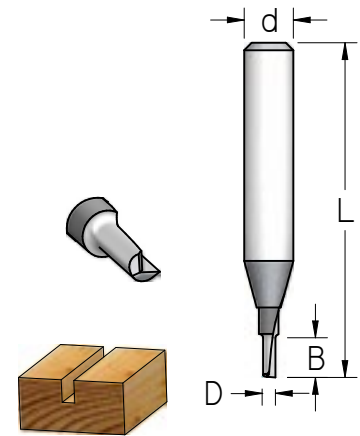

P1

Single Flute

Tool No.		D	B	L
d=6mm	d=1/4"	mm	mm	mm
P130633	P130634	6.3	19	51
P140633	P140634	6.3	25	57
P131273	P131274	12.7	19	51
P131603	P131604	16.0	19	51
P131903	P131904	19.0	19	51

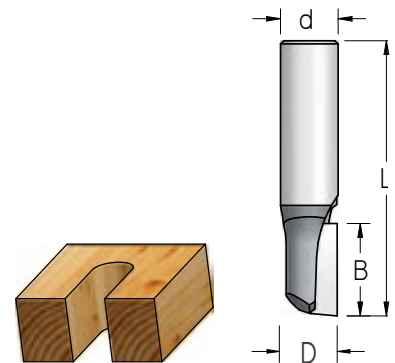

Tool No.		D	B	L
d=12mm	d=1/2"	mm	mm	mm
P130632	P130638	6.3	19	63
P140952	P140958	9.5	25	70
P150952	P150958	9.5	32	76
P141272	P141278	12.7	25	67
P151272	P151278	12.7	32	73
P161272	P161278	12.7	38	80
P181272	P181278	12.7	51	108

P...L

Left Hand Straight Plunge Cutting Bits

2 Flutes, left hand rotation

Tool No.		D	B	L
d=12mm	d=1/2"	mm	mm	mm
P230632L	P230638L	6.3	19	63
P241272L	P241278L	12.7	25	67
P281272L	P281278L	12.7	51	108

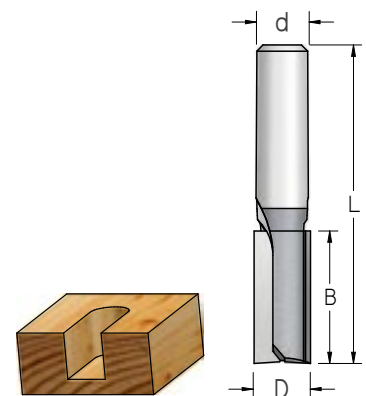



P3, P3U

Straight Plunge Cutting Bits - 3 Flutes

Hard K-Carbide grade.

For better surface finish and longer tool life than tools with 2 flutes

Tool No.		D	B	L
d=12mm	d=1/2"	mm	mm	mm
P381272	P381278	12.7	51	108
Up Shear				
P3U4102	P3U4108	9.5	25	71
P3U6122	P3U6128	12.7	38	84

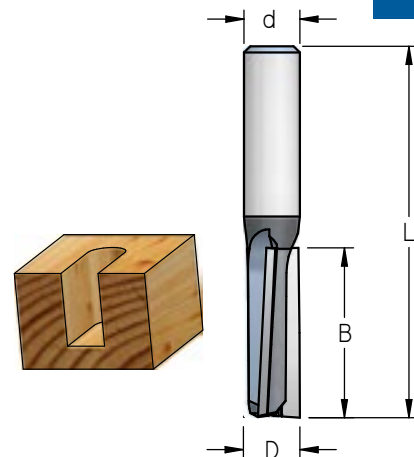

PU

Up Shear - Straight Bits

Heavy duty, faster feed rate and increased tool life. For deep grooving in hard wood, MDF and other man made materials.

2 Flutes

Tool No.		D	B	L
d=12mm	d=1/2"	mm	mm	mm
PU40952	PU40958	9.5	25	70
PU41272	PU41278	12.7	25	67
PU51272	PU51278	12.7	32	73
PU61272	PU61278	12.7	38	80
PU81272	PU81278	12.7	51	108
PU51902	PU51908	19.0	32	73
PU52542	PU52548	25.4	32	73

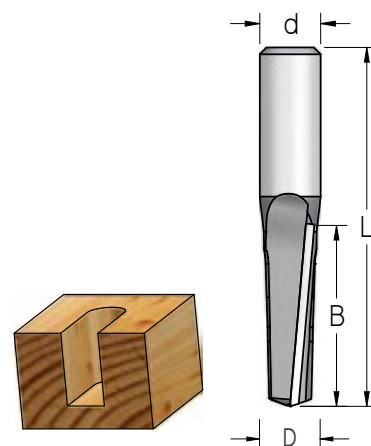

PS

Down Shear - Straight Bits

For smoother cut and cleaner edge of laminated boards. Directs chips towards the work piece.

2 Flutes

Tool No.		D	B	L
d=12mm	d=1/2"	mm	mm	mm
PS51272	PS51278	12.7	32	73
PS81272	PS81278	12.7	51	108

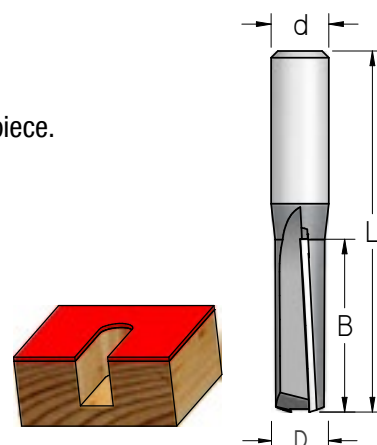

STAGGER TOOTH STRAIGHT BITS

For fast stock removal like a single flute, but better balanced and increased strength.

1 + 1 Flutes

ST

Stagger Tooth Plunge Cutting Bits

Tool No.		D	B	L
d=12mm	d=1/2"	mm	mm	mm
ST61272	ST61278	12.7	38	80
ST81272	ST81278	12.7	51	108
ST91272	ST91278	12.7	57	114
ST01272	ST01278	12.7	63	114

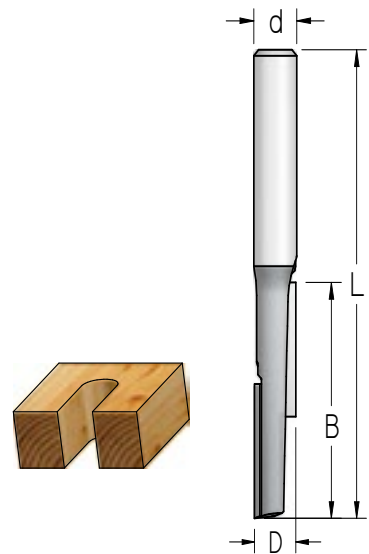

STS

Stagger Straight Shear Bits

Up and down shear angle. For cleaner edges of double faced boards, plywoods and natural woods.

Tool No.		D	B	L
d=12mm	d=1/2"	mm	mm	mm
STS6132	STS6138	12.7	38	79
STS9132	STS9138	12.7	57	108

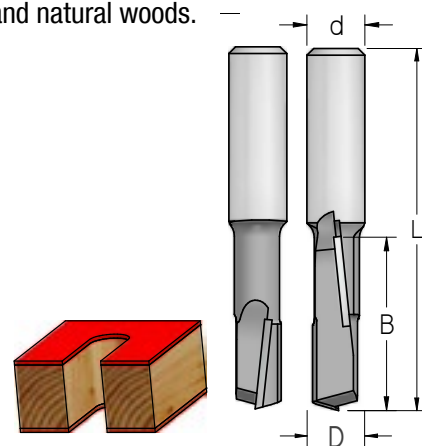

STD, STP

Stagger Straight Bits

With carbide boring point. For better plunging into hard materials.

Tool No.		D	B	L
d=12mm	d=1/2"	mm	mm	mm
Down Shear				
STD9132	STD9138	12.7	57	118
Up and Down Shear				
STP9132	STP9138	12.7	57	118

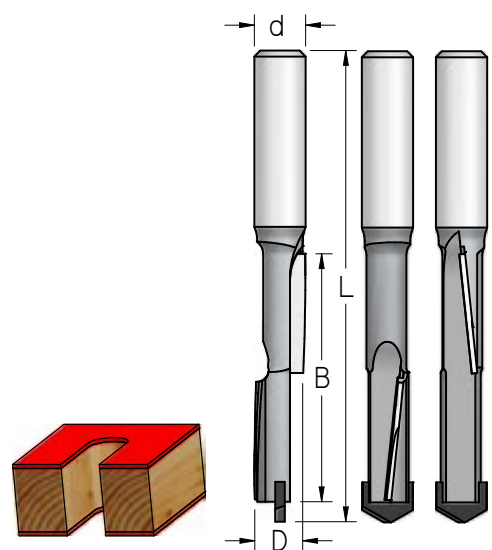

MORTISING BITS

MB

Hinge Mortising Bits

This special design is best for plunging and mortising shallow grooves.

Tool No.		D	B	L
d=6mm	d=1/4"	mm	mm	mm
MB31273	MB31274	12.7	19	51
MB31603	MB31604	16.0	19	51
MB31903	MB31904	19.0	19	51

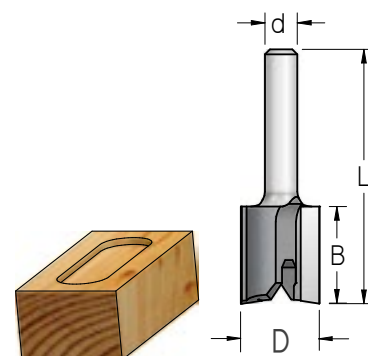

MB...O

Lock Mortising Cutters – Screw Type

2 Flutes

Tool No.	D mm	B mm	L mm
Straight Cut			
P220630	6.3	12	34
P220990	10	15	34
Down Shear			
MB08000	12.7	15	
MB10010	16.0	15	
MB12020	19.0	15	
MB14010	22.2	15	
MB16010	25.4	15	
MB18010	28.6	15	
MB20000	31.8	16	

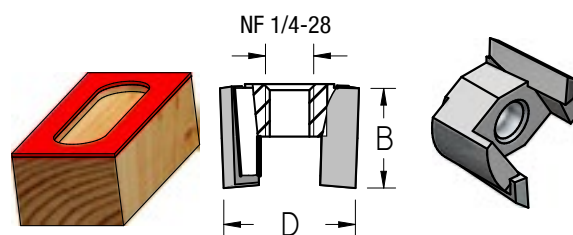
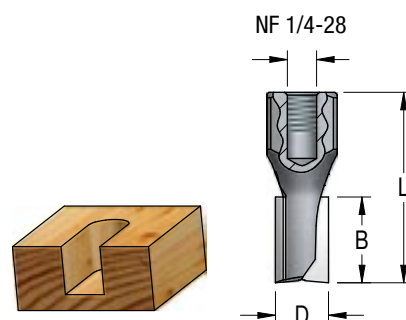

NMB

Arbors for Mortising Cutters – Screw Type

Tool No.		D	L		
d=6mm	d=1/4"	d=12mm	d=1/2"	mm	
NMB0013	NMB0014		NF 1/4-28	40	
		NMB0032	NMB0038	NF 1/4-28	38
		NMB0012	NMB0018	NF 1/4-28	60

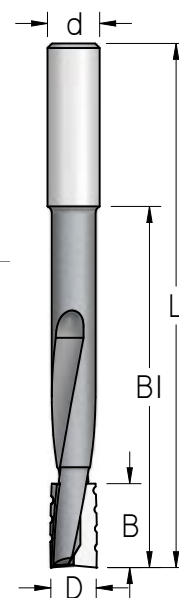
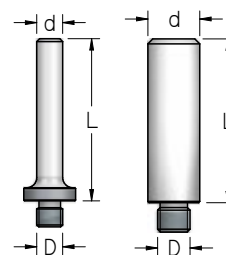

DT

Mortising Bits for Lock Case

Up-Shear spiral design for deep grooving. Carbide tipped with chip breaker. For cutting mortise slots in doors and furniture with reciprocating feed motion.

Tool No.		D	B	B1	L	
d=12mm	d=1/2"	d=16mm	mm	mm	mm	
DT12702	DT12708		12.7	25	72	151
DT14002	DT14008	DT14001	14.0	25	110	160
DT16002M	DT16008M		16.0	25	80	130
DT16002	DT16008	DT16001	16.0	25	120	170
DT18002	DT18008	DT18001	18.0	25	120	170
DT19002	DT19008		19.0	25	120	170

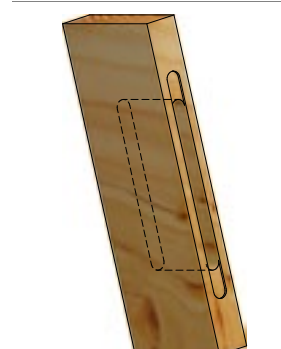

CNC STRAIGHT PRODUCTION BITS **Up-Shear** POWER

The shearing action of the US and UB series yields cleaner cuts with less energy and less vibration than the standard straight bits. The helical ground razor-sharp cutting edges provide superior finish. Spiral upshear geometry pulls the chips from the working area, allowing deeper penetration with higher feed rates. The result is – long tool life during CNC operations at an affordable price. The use of these tools can prove, in many cases, to be more economical than the use of expensive spiral solid carbide tools. Using the Chipbreaker (Semi-finishing) - UB - Up-Shear Bits allows even higher feed rates leaving a relatively smooth surface finish. Designed for CNC machines, the tools are available with large shank diameters.

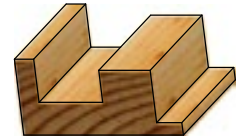

US2

2 Flutes

Tool No.		D	B	B1	L
d=12mm	d=1/2"	d=16mm	d=20mm	mm	mm
2 Flutes					
US25132	US25138	12.7	32	45	90
US27132	US27138	12.7	42	55	105
	US25161	16.0	32	50	100
	US27161	16.0	42	60	110
	US2720E	20.0	42	60	120
2+2 Flutes					
US28132	US28138	13.0	50	60	110
	US2820E	20.0	50	65	125

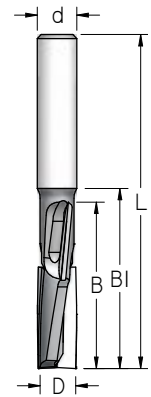
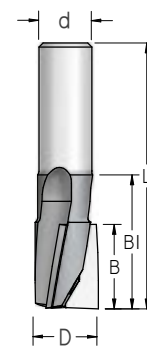
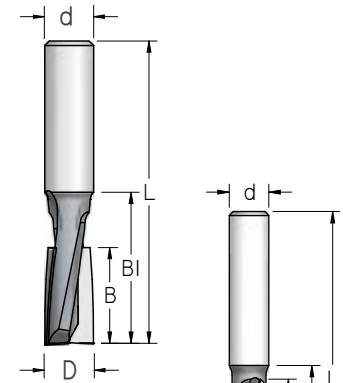

US3

3 Flutes

Tool No.		D	B	B1	L
d=16mm	d=20mm	mm	mm	mm	mm
US35161		16.0	32	50	100
	US3820E	20.0	50	65	125

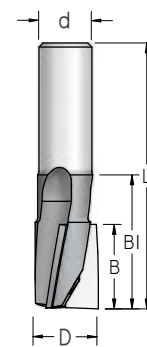

UB2

2 Flutes with Chipbreaker.
For roughing and semi finishing.

Tool No.		D	B	B1	L
d=12mm	d=1/2"	d=16mm	d=20mm	mm	mm
2 Flutes					
UB27132	UB27138	13.0	42	55	105
		45	90		
2+2 Flutes					
UB28132	UB28138	13.0	50	60	110

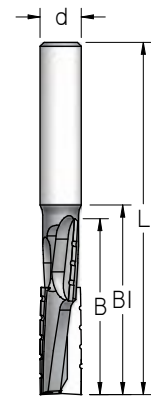
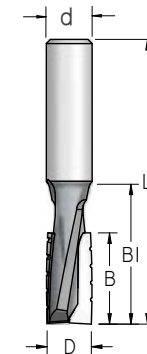

UB3

3 Flutes with Chipbreakers

Tool No.		D	B	B1	L
d=16mm	d=20mm	mm	mm	mm	mm
UB35161		16.0	32	50	100
	UB3820E	20.0	50	65	125

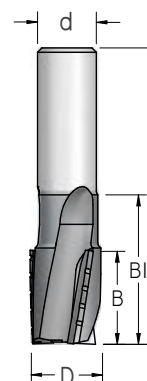

PF TEMPLATE ROUTER BITS

Plunge-cutting straight Bits with shank mounted (top) bearing pilot.

This type of flush trim bits is designed for template / pattern routing from simple cuts to complex curves.

The bearing has the same Diameter as the cutter and it enables following pre-shaped templates and forming an exact duplicate of the template. Ideal for producing identical parts when needed.

As the bearing is mounted on the shank, it has been limited to relatively big cutter Diameters. WPW has developed unique Line of tools (PFT), which enables us to offer smaller cutters than ever, as small as 4.8mm!

PF

Straight Plunge Template Bits

Tool No.		D	B	L	Ball Bearing	Retaining Collar
d=6mm	d=1/4"	d=8mm	mm	mm	mm	
PF10953	PF10954		9.5	6.5	44.5	B095063 PF06300
PF20953	PF20954		9.5	13	51	B095063 PF06300
PF30953	PF30954		9.5	19	56	B095063 PF09500
PF40953	PF40954		9.5	25	63	B095063 PF06300
		PF41205 /K	12.0	25	70	B120080 x2 PF08010
PF11273	PF11274		12.7	7	50	B127063 PF06300
PF11303	PF11304		12.7	9.5	57	B127063 PF06300
PF11313	PF11314*		12.7	9.5	60	B159063 PF06300
PF21273 /K	PF21274 /K		12.7	13	50	B127063 PF06300
PF31273	PF31274		12.7	19	57	B127063 PF06300
PF41273 /K	PF41274 /K		12.7	25	63	B127063 PF06300
PF51273 /K	PF51274 /K		12.7	32	70	B127063 PF06300
PF41603	PF41604		16.0	25	63	B159063 PF06300
		PF41605 /K	16.0	25	67	B160080 PF08000
		PF51605 /K	16.0	32	73	B160080 PF08000
PF41903	PF41904		19.0	25	63	B190063 PF06300
		PF42605	26.0	25	70	B260100 PF10000

*Fits Porter Cable kit model #59370 - Door Hinge template

Tool No.		D	B	L	Ball Bearing	Retaining Collar
d=12mm	d=1/2"	mm	mm	mm		
PF31902	PF31908	19.0	19	70	B190127 x2	PF19000
PF41902 /K	PF41908 /K	19.0	25	77	B190127 x2	PF19000
PF81902 /K	PF81908 /K	19.0	51	102	B190127 x2	PF19000
PF72542	PF72548	25.4	45	96	B254127	PF19000
PF62852 /K	PF62858 /K	28.6	38	90	B285127	PF12700
PF82852	PF82858	28.6	51	103	B285127	PF12700



K- Can be ordered with Harder K-Carbide. While ordering, just add the letter "K" to the Tool No.

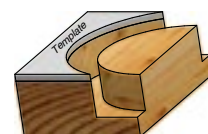
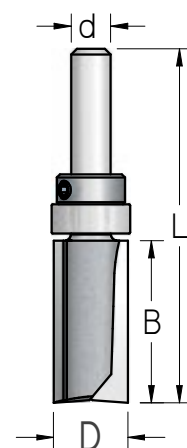



PFS

Straight Down Shear Template Bits

For better finish on laminates.

Tool No.		D	B	L	Ball Bearing	Retaining Collar
d=12mm	d=1/2"	mm	mm	mm		
PFS5192 /K	PFS5198 /K	19.0	32	83	B190127 x2	PF19000
PFS6192 /K	PFS6198 /K	19.0	38	89	B190127 x2	PF19000
PFS8192 /K	PFS8198 /K	19.0	51	102	B190127 x2	PF19000



K- Can be ordered with Harder Carbide. While ordering, just add the letter "K" to the Tool No.

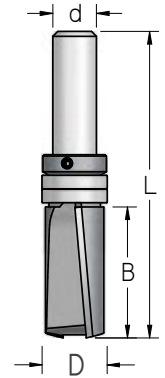
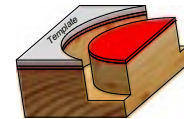

P3F

Straight Plunge Template Bits - 3 Flutes

For better surface finish and longer tool life than tools with 2 flutes.

Tool No.				D	B	L	Ball Bearing	Retaining Collar
d=6mm	d=1/4"	d=12mm	d=1/2"	mm	mm	mm		
P3F2103	P3F2104			9.5	12	50	B095063	PF09500
P3F4123	P3F4124			12.7	25	63	B127063	PF06300
		P3F4192 /K	P3F4198 /K	19	25	76	B190127 x2	PF19000
		P3F5192 /K	P3F5198 /K	19	32	84	B190127 x2	PF19000

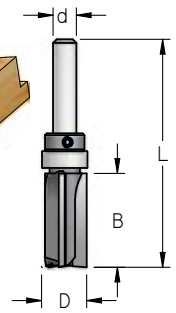
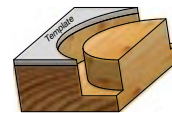

Up Shear

P3FU2103	P3FU2104			9.5	12	50	B095063	PF09500
P3FU4123 /K	P3FU4124 /K			12.7	25	63	B127063	PF06300
		P3FU1192	P3FU1198	19	10	81	B190127 x2	PF19000
		P3FU4192 /K	P3FU4198/K	19	25	76	B190127 x2	PF19000

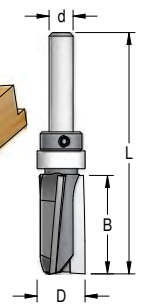
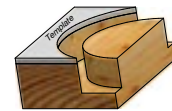

Down Shear

P3FS2103	P3FS2104			9.5	12	50	B095063	PF09500
P3FS4123 /K	P3FS4124 /K			12.7	25	63	B127063	PF06300
		P3FS4192 /K	P3FS4198/K	19	25	76	B190127 x2	PF19000

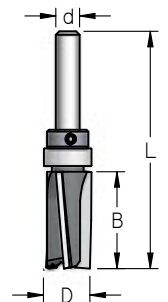
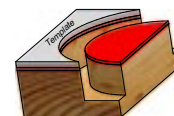

K- Can be ordered with Harder Carbide. While ordering, just add the letter "K" to the Tool No.

PFT

Mini Straight Template Bits

Template routing is now possible with a smaller cutter than ever!

The top bearings have the same Diameter as the shank, or even smaller. Important feature in jobs with complex shapes when small diameter cutters are needed. Allows getting into tighter corners.

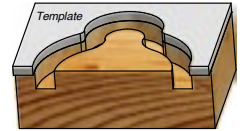

Tool No.	D	B	L	Ball Bearing
d=1/8" (3.17mm)	mm	mm	mm	
1/8" Shank for CNC Routers, Dremel and equivalent rotary machines				
PFT2048i	4.8	12	50	B048024
PFT1063i	6.3	6	50	B063032

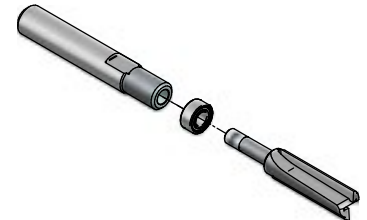

Tool No.	D	B	L	Ball Bearing
d=6mm d=1/4"	mm	mm	mm	
PFT10483 PFT10484	4.8	6.5	47	B048024
PFT20483 PFT20484	4.8	12	51	B048024
PFT10633 PFT10634	6.3	6.5	49	B063032
PFT30633 PFT30634	6.3	19	62	B063032

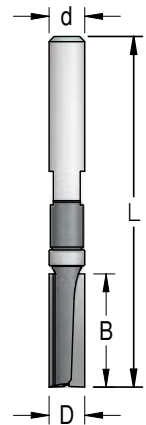

Tool No.	D	B	L	Ball Bearing
d=12mm d=1/2"	mm	mm	mm	
PFT40952 PFT40958	9.5	25	82	B095063
PFT51272 PFT51278	12.7	32	90	B127063

PFM

Straight Plunge Template Bits with 2 Replaceable Carbide Blades

Reduces set-up time and is cost effective. Supplied with Torx Key.

Tool No.	D	B	L	Blade No.	Ball Bearing	Retaining Collar
d=12mm d=1/2"	mm	mm	mm			
2 gripping screws						
PFM7192 PFM7198	19.0	50	100	CM05012 x2	B190127 x2	PF19000
3 gripping screws for heavy duty tasks						
PFM8192 /K PFM8198 /K	19.0	50	100	CM501217 x2	B190127 x2	PF19000

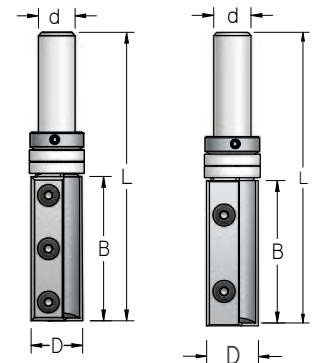

K- Can be ordered with Harder K-Carbide. While ordering, just add the letter "K" to the Tool No.
Torx Screw – BT40060

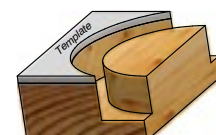

FP MULTI TRIMMERS

These multi purpose cutters integrate the standard flush trim bits - bottom bearing, with the template bits - top bearing. It allows the cutter to be used with the template mounted on either side of the work. Consequently, it is possible to cut from either direction, using only one template and without moving the template to the other side of the workpiece. This is especially useful when cutting curves which run both with and against the grain.

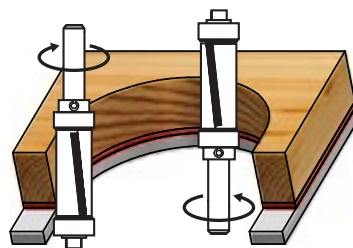

FPS

Down Shear Multi Trimmer

Ensures a clean cut even in difficult materials.

Tool No.		D	B	L	Ball Bearing	Retaining Collar
d=12mm	d=1/2"	mm	mm	mm		
FPS5192	FPS5198	19.0	32	96	B190127 x2	PF19000
FPS8192	FPS8198	19.0	51	114	B190127 x2	PF19000

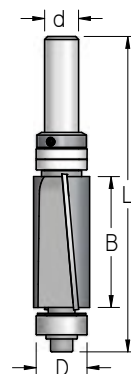

F4P

4 Flutes Multi Trimmer

For better surface finish and longer tool life in hard wood, solid surface and similar materials.

Tool No.		D	B	L	Ball Bearing	Retaining Collar
d=12mm	d=1/2"	mm	mm	mm		
F4P8192	F4P8198	19.0	51	117	B190063 + B190127 x 2	PF19000



FPM

Multi Trimmer with 2 replaceable Carbide Blades

Reduces set up time and cost effective.

3 gripping screws for heavy duty tasks.

Supplied with Torx Key.

Tool No.		D	B	L	Blade No.	Ball Bearing	Retaining Collar
d=12mm	d=1/2"	mm	mm	mm			
FPM1922 /K	FPM1928 /K	19.0	50	118	CM501217 x2	B190063 + B190127 x 2	PF19000

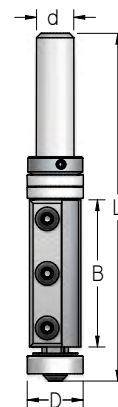

K- Can be ordered with Harder K-Carbide. While ordering, just add the letter "K" at the end of the Tool No.
Replacement Torx Screw – BT40060

FLUSH TRIM BITS

With Ball Bearing Guide.

F2

2 Flutes

Tool No.	D	B	L	Ball Bearing
d=1/8" (3.17mm)	mm	mm	mm	
1/8" Shank for CNC Routers, Dremel and equivalent rotary machines				
F21048i	4.8	10	44	B048024

Tool No.	D	B	L	Ball Bearing	
d=6mm	d=1/4"	mm	mm	mm	
Nano Flush Trimmers with Miniature Bearing					
F210483	F210484	4.8	11	51	B048024
F230483	F230484	4.8	19	61	B048024

Tool No.	D	B	L	Ball Bearing		
d=6mm	d=1/4"	d=8mm	mm	mm		
F220633	F220634		6.3	13	52	B063032
F230633	F230634		6.3	19	57	B063032
F240633	F240634	F240635	6.3	25	63	B063032
F250633	F250634		6.3	32	70	B063032
F240803	F240804		8.0	25	66	B080040
F220953 /K	F220954 /K	F220955 /K	9.5	13	53	B095048
F240953 /K	F240954 /K	F240955 /K	9.5	25	65	B095048
F250953 /K	F250954 /K		9.5	32	67	B095048
F221273 /K	F221274 /K	F221275 /K	12.7	13	53	B127048
F241273 /K	F241274 /K	F241275 /K	12.7	25	65	B127048
F251273 /K	F251274 /K		12.7	32	71	B127048
		F271275 /K	12.7	42	86	B127048

Tool No.	D	B	L	Ball Bearing	
d=12mm	d=1/2"	mm	mm	mm	
Nano Flush Trimmers with Miniature Bearing					
F221272 /K	F221278 /K	12.7	13	63	B127048
F241272 /K	F241278 /K	12.7	25	80	B127048
F251272 /K	F251278 /K	12.7	32	90	B127048
F261272 /K	F261278 /K	12.7	38	96	B127048
F281272 /K	F281278 /K	12.7	51	115	B127048
F241902	F241908	19.0	25	76	B190063

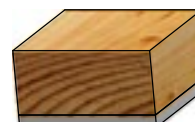
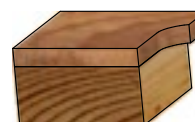
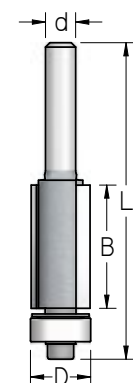
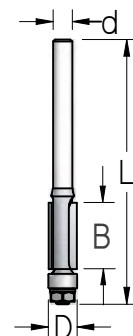

K- Can be ordered with Harder K-Carbide. While ordering, just add the letter "K" at the end of the Tool No.



F3

3 Flutes

For better surface finish and longer tool life in hard materials – wood, solid surface and others

d=6mm	Tool No.	D	B	L	Ball Bearing	
d=1/4"	d=8mm	mm	mm	mm		
F321273 /K	F321274 /K	12.7	13	53	B127048	
F341273 /K	F341274 /K	F341275	12.7	25	65	B127048

d=12mm	Tool No.	D	B	L	Ball Bearing
d=1/2"		mm	mm	mm	
F321272	F321278	12.7	13	63	B127048
F341272 /K	F341278 /K	12.7	25	80	B127048
F361272 /K	F361278 /K	12.7	38	96	B127048
F381272 /K	F381278 /K	12.7	51	115	B127048

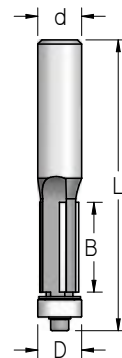

K- Can be ordered with Harder K-Carbide. While ordering, just add the letter "K" at the end of the Tool

F4

4 Flutes

For better surface finish and longer tool life in hard wood, solid surface and similar materials.

d=12mm	Tool No.	D	B	L	Ball Bearing
d=1/2"		mm	mm	mm	
F441902	F441908	19.0	25	75	B190063
F461902	F461908	19.0	38	99	B190063
F481902	F481908	19.0	51	105	B190063

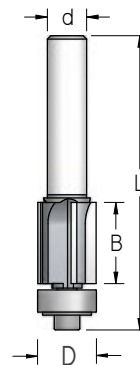
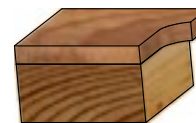
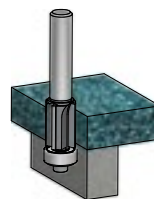

F2/F3

Double Bearing Flush Trim Bits

For added stability.

d= 6mm	Tool No.	D	B	L	Flutes	Ball Bearing
d=1/4"		mm	mm	mm		
F240983	F240984	9.5	25	71	2	B095048 x2

d=12mm	Tool No.	D	B	L	Flutes	Ball Bearing
d=1/2"		mm	mm	mm		
F261282 /K	F261288 /K	12.7	38	103	2	B127048 x2
F361282 /K	F361288 /K	12.7	38	103	3	B127048 x2
F281282 /K	F281288 /K	12.7	51	111	2	B127048 x2

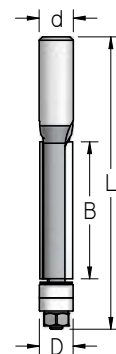
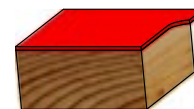

K- Can be ordered with Harder K-Carbide. While ordering, just add the letter "K" at the end of the Tool

FM

Flush Trim Bit with replaceable Carbide Blades

Reduces set up time and cost effective.

Supplied with Torx Key.

Tool No.		D	B	L	Blade No.	Ball Bearing	
d=6mm	d=1/4"	d=8mm	mm	mm	mm		
FM19003	FM19004	FM19005	19.0	12	52	CM01212 x2	B190060
FM19013 /K	FM19014 /K	FM19015 /K	19.0	30	70	CM03012b x2	B190060

Tool No.		D	B	L	Blade No.	Ball Bearing
d=12mm	d=1/2"	mm	mm	mm		

2 gripping screws

FM19012 /K	FM19018 /K	19.0	30	79	CM03012b x2	B190060
------------	------------	------	----	----	-------------	---------

3 gripping screws for heavy duty tasks

FM19022 /K	FM19028 /K	19.0	50	110	CM501217 x2	B190060
------------	------------	------	----	-----	-------------	---------



K- Can be ordered with Harder K-Carbide. While ordering, just add the letter "K" at the end of the Tool No.
Replacement Torx Screw – BT40060

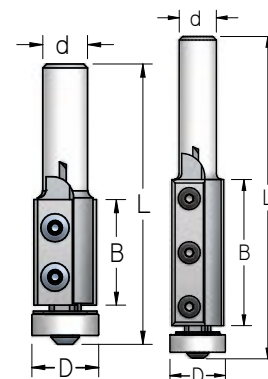

FO

Overhang Trim Bits

Used when the upper panel should overhang the side panel.

Common for making lighted sign letters.

Tool No.		C	D	B	L	Ball Bearing
d=6mm	d=1/4"	mm	mm	mm	mm	
F020953	F020954	0.75	9.5	13	53	B110050
F021953	F021954	0.25	9.5	13	53	B100050

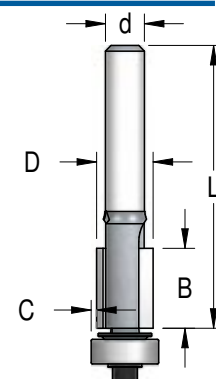
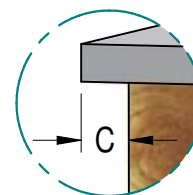

FT

Double Sided Laminate Trimmer

Up/Down shear cutter assembly. Can be used for laminated boards of thickness 11mm up to 35mm

Tool No.		D	B	B1	L	Ball Bearing	
d=6mm	d=1/4"	d=8mm	mm	mm	mm		
FT51273	FT51274	FT51275	12.7	35	13	65	B127063

Tool No.		D	B	B1	L	Ball Bearing
d=12mm	d=1/2"	mm	mm	mm	mm	
FT51272	FT51278	12.7	35	13	79	B127063

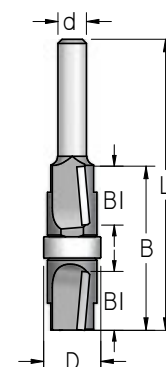
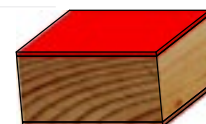

FU

Up Shear Flush Trim Bits

For Faster Feed Rates.

Tool No.		D	B	L	Ball Bearing
d=6mm	d=1/4"	mm	mm	mm	
FU41273	FU41274	12.7	25	80	B127048

Tool No.		D	B	L	Ball Bearing
d=12mm	d=1/2"	mm	mm	mm	
FU61902	FU61908	19.0	38	100	B190063
FU81902	FU81908	19.0	51	113	B190063

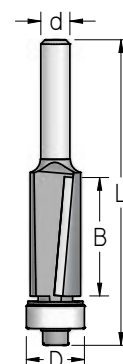

FS

Down Shear Laminate Trimmers

Eliminates chipping, cleaner edge when trimming veneered plywood and laminated boards.

Tool No.		D	B	L	Ball Bearing
d=6mm	d=1/4"	mm	mm	mm	
FS20953 /K	FS20954 /K	9.5	13	53	B095048
FS41273 /K	FS41274 /K	12.7	25	65	B127048
F221603 /K	F221604 /K	16.0	16	55	B160050
F221903 /K	F221904 /K	19.0	16	61	B190063

Tool No.		D	B	L	Ball Bearing
d=12mm	d=1/2"	mm	mm	mm	
FS41272 /K	FS41278 /K	12.7	25	80	B127048
FS61902	FS61908	19.0	38	100	B190063
FS81902	FS81908	19.0	51	113	B190063

 **K-** Can be ordered with Harder K-Carbide. While ordering, just add the letter "K" at the end of the Tool No.

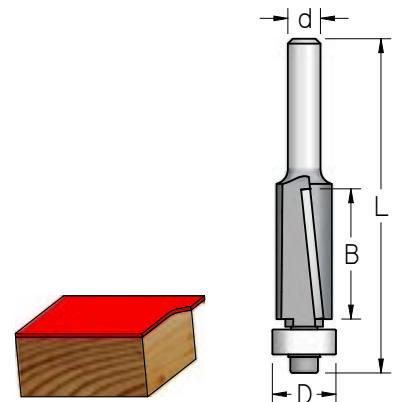

FSG

Laminate Trimmers with Adhesive Trapping Gap

Smooth guiding despite excess of glue.

Tool No.		D	B	B1	L	Ball Bearing
d=6mm	d=1/4"	mm	mm	mm	mm	
FSG1273 /K	FSG1274 /K	12.7	25	8	72	B127048

Tool No.		D	B	B1	L	Ball Bearing
d=12mm	d=1/2"	mm	mm	mm	mm	
FSG1272 /K	FSG1278 /K	12.7	25	8	82	B127048

 **K-** Can be ordered with Harder K-Carbide. While ordering, just add the letter "K" at the end of the Tool No.

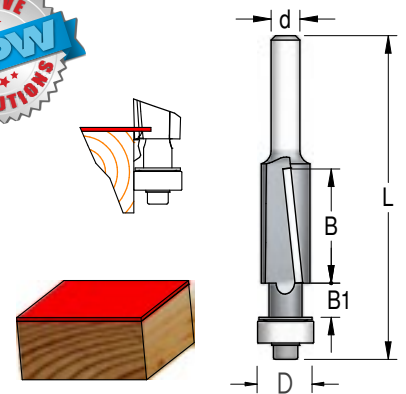

BEVEL TRIM BITS

SL

Bevel Trim Bit - Down Shear

Smooth guiding despite excess of glue.

The combination of 8° bevel and the down shear flute design, ensures a perfect clean finish on laminates.

Tool No.		a	D	B	L	Ball Bearing
d=6mm	d=1/4"	degrees	mm	mm	mm	
SL20803 /K	SL20804 /K	8	16	12	58	B127048

 **K-** Can be ordered with Harder K-Carbide. While ordering, just add the letter "K" at the end of the Tool No.

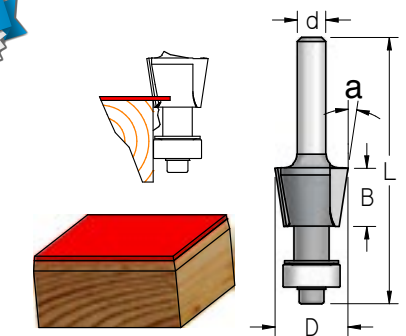

SL

Nano Bevel Trim bits with Miniature Bearing

2 Flutes

Tool No.		a	D	B	L	Ball Bearing
d=6mm	d=1/4"	degrees	mm	mm	mm	
SL00073	SL00074	7	6.3	8	48	B048024
SL00223	SL00224	22.5	12.7	12	48	B048024
SL00453	SL00454	45	14.3	6.3	48	B048024

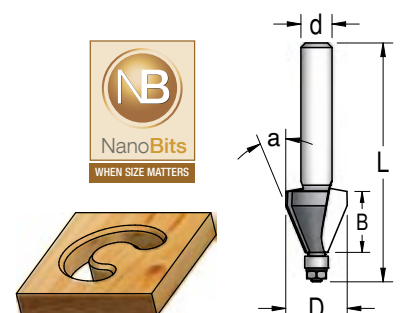

SL2

Bevel Trim bits - 2 Flutes

Tool No.		a	B	L	Ball Bearing
d=6mm	d=1/4"	degrees	mm	mm	
MSL2453	MSL2454	45	6	45	B080040
SL21123	SL21124	11.25	22	67	B127048
SL21503	SL21504	15	6	51	B127048
SL21513	SL21514	15	16	60	B127048
SL22503	SL22504	25	6	51	B127048
SL22513	SL22514	25	16	51	B095048
SL24503	SL24504	45	6	51	B127048
SL24513	SL24514	45	11	51	B127048

Tool No.		a	B	L	Ball Bearing
d=12mm	d=1/2"	degrees	mm	mm	
SL22252	SL22258	22.5	22	73	B127048
SL22512	SL22518	25	18	66	B127048
SL24512	SL24518	45	11	62	B127048
SL24532	SL24538	45	19	70	B127048
SL24542	SL24548	45	25	73	B127048

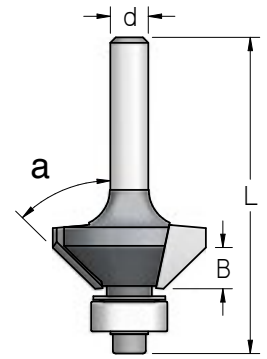
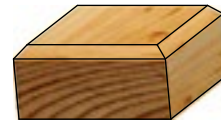

SL3

Bevel Trim bits - 3 Flutes

For better surface finish and longer tool life.

Tool No.		a	B	L	Ball Bearing
d=6mm	d=1/4"	degrees	mm	mm	
SL30703 /K	SL30704 /K	7	10	51	B160050
SL31503 /K	SL31504 /K	15	10	51	B160050
SL32203 /K	SL32204 /K	22	10	51	B160050
SL33003	SL33004	30	10	51	B160050
SL34503	SL34504	45	11	51	B127048

Tool No.		a	B	L	Ball Bearing
d=12mm	d=1/2"	degrees	mm	mm	
SL34502	SL34508	45	11	62	B127048

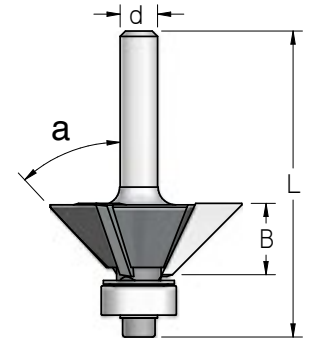
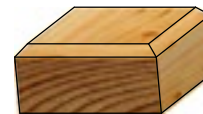

K- Can be ordered with Harder K-Carbide. While ordering, just add the letter "K" at the end of the Tool No.

SL

3° Patternmaker

For making wood vacuum-forming molds.

It can be used to bevel the leading edge on a door.

Tool No.		a	D	B	L	Ball Bearing
d=12mm	d=1/2"	degrees	mm	mm	mm	
SL20392	SL20398	3	12.7	54	117	B127048

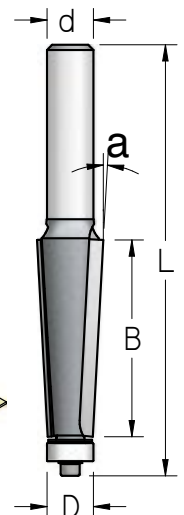
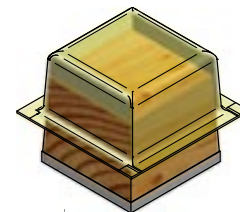

SZ

Bevel Trimming Bits with no bearing – 3 flutes

Tool No.		a	D	B	L
d=12mm	d=1/2"	degrees	mm	mm	mm
SZ34502	SZ34508	45	35	10	60

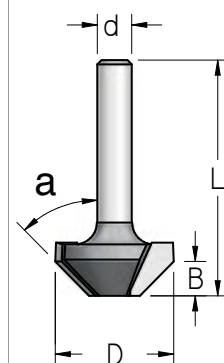
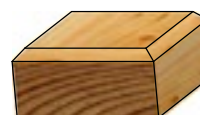

RABBETING BITS

With Ball Bearing Guide.

Tools with 3 and 4 flutes are recommended, when a smooth finish is required and for hard materials.

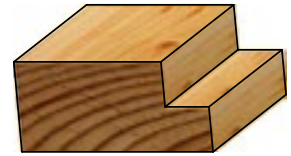

E2

2 Flutes

Tool No.		C	D	B	L	Ball Bearing
d=6mm	d=1/4"	mm	mm	mm	mm	
Nano Flush Trimmers with Miniature Bearing						
E200163	E200164	1.5	7.9	12	50	B048024
E200323	E200324	3.2	11.1	13	47	B048024

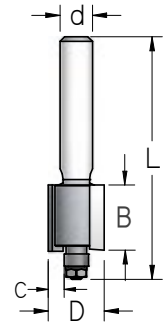

d=6mm	Tool No.	d=8mm	C	D	B	L	Ball Bearing
	d=1/4"		mm	mm	mm	mm	
E220503	E220504		4.8	22.2	12.5	49	B127048
E220953	E220954	E220955	9.5	31.8	12.5	51	B127048
E221113	E221114	E221115	11.1	31.8	12.5	51	B095048
E221273	E221274		12.7	35.0	12.5	51	B095048

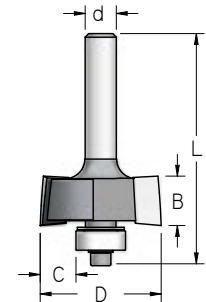

Tool No.		C	D	B	L	Ball Bearing
d=12mm	d=1/2"	mm	mm	mm	mm	
E220952	E220958	9.5	31.8	12.5	59	B127048
E221112	E221118	11.1	31.8	12.5	59	B095048
E221272	E221278	12.7	35.0	12.5	59	B095048

E3

3 Flutes

For better surface finish and longer tool life.

Tool No.		C	D	B	L	Ball Bearing
d=6mm	d=1/4"	mm	mm	mm	mm	
E320323	E320324	3.2	19.0	12.5	51	B127048
E320503	E320504	4.8	22.2	12.5	49	B127048

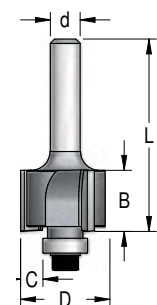

E4

4 Flutes

For better surface finish and longer tool life.

Tool No.		C	D	B	L	Ball Bearing
d=6mm	d=1/4"	mm	mm	mm	mm	
E420953	E420954	9.5	31.8	12.5	49	B127048

Tool No.		C	D	B	L	Ball Bearing
d=12mm	d=1/2"	mm	mm	mm	mm	
E420952	E420958	9.5	31.8	12.5	59	B127048

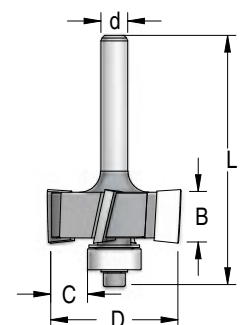

E33

Extra Large Rabbeting Bits - 3 Flutes

Tool No.		C	D	B	L	Ball Bearing
d=12mm	d=1/2"	mm	mm	mm	mm	
E331502	E331508	15	52.0	19	77	B220060
E331652	E331658	16.5	52.0	19	77	B190060
E331852	E331858	18.5	52.0	19	77	B150060
E332002	E332008	20	52.0	19	77	B120060 x2

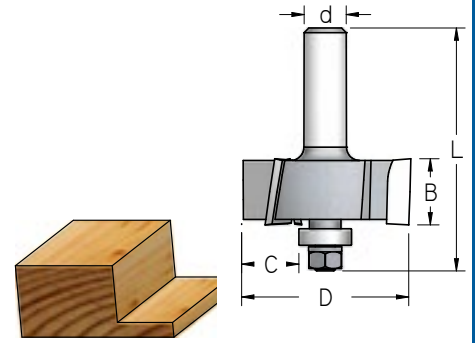

EM

Rabbeting bit with replaceable blades

Reduces set up time and cost effective. 2 Flutes.
Supplied with Torx key.

Tool No.		C	D	B	L	Ball Bearing	Blade No.	
d=8mm	d=12mm	d=1/2"	mm	mm	mm	mm		
EM21275 /K			12.7	35.0	12	54	B095063	CM01212 /K
	EM21272 /K	EM21278 /K	12.7	35.0	12	65	B095063	CM01212 /K

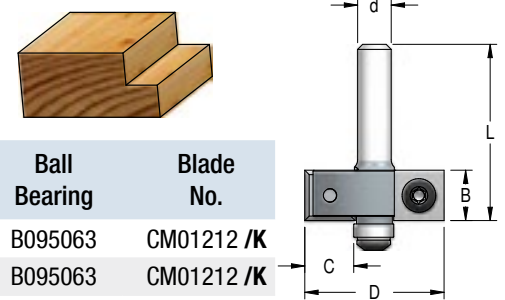

K- Can be ordered with Harder K-Carbide. While ordering, just add the letter "K" at the end of the Tool No.
Replacement Torx Screw – BT40060

ES

Rabbeting Set - 2 flutes

4 Ball Bearing guides for different rabbets.

Tool No.		D	B	L	C	Ball Bearing
d=6mm	d=1/4"	d=8mm	mm	mm	mm	
ES20003	ES20004	31.8	12.5	60	6.3	B190063
					8.0	B159063
					9.5	B127063
					11	B095063
ES20005	31.8	12.5	60	6.3	B190048	
				8.0	B160048	
				9.5	B127048	
				11	B095048	

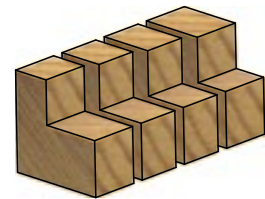
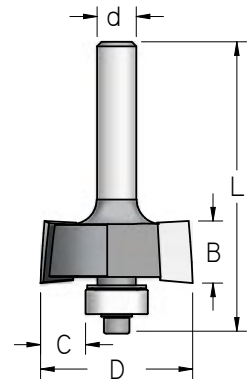

Tool No.		D	B	L	C	Ball Bearing
d=12mm	d=1/2"	mm	mm	mm	mm	
ES20002	ES20008	31.8	12.5	65	6.3	B190063
					8.0	B159063
					9.5	B127063
					11	B095063



E4S

Rabbeting Set - 4 flutes

5 Ball Bearing guides for different rabbets

Tool No.		D	B	L	C	Ball Bearing
d=12mm	d=1/2"	mm	mm	mm	mm	
					6.5	B220080
					8.0	B190063
E4S3502	E4S3508	35.0	24	79	9.5	B159063
					11.1	B127063
					12.7	B095063 x 2

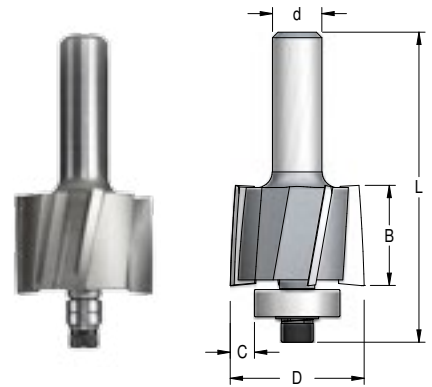
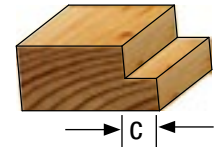

Table for choosing the tool and ball bearing guide, according to the required rabbet (C)

Before ordering another tool, remember to check if you can achieve the new desired rabbet by changing the ball bearing.



Tool No.		Ball Bearing								
d=6mm	d=1/4"	d=8mm	c=1.6	c=3.2	c=4.8	c=6.3	c=7.9	c=9.5	c=11.1	c=12.7
E200163	E200164		B048024							
E200323	E200324			B048024						
E220503	E220504		B190048	B160048	B127048	B095048				
E220953	E220954	E220955				B190048	B160048	B127048	B095048	
E221273	E221274					B190048	B160048	B127048	B095048	
E320323	E320324		B160048	B127048	B095048					
E320503	E320504		B190048	B160048	B127048	B095048				
E420953	E420954					B190048	B160048	B127048	B095048	
	EM21275						B190063	B159063	B127063	B095063

Tool No.		Ball Bearing				
d=12mm	d=1/2"	c=6.3	c=7.9	c=9.5	c=11.1	c=12.7
E220952	E220958	B190048	B160048	B127048	B095048	
E221272	E221278		B190048	B160048	B127048	B095048
E420952	E420958	B190048	B160048	B127048	B095048	
EM21272	EM21278		B190063	B159063	B127063	B095063

PANEL PILOT BITS

Carbide Tipped with hardened pilot and boring point.
 Panel Pilot Bits are designed for fast cut out work, using a template.
 Widely used in the caravan industry.

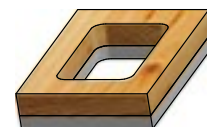

PPC

Single Concave Flute

For better chip flow and longer tool life.

Tool No.		D	B	L
d=6mm	d=1/4"	mm	mm	mm
PPC0633	PPC0634	6.3	19	63
	PPC0956	9.5	25	79
	PPC1272	12.7	30	89
	PPC1278	12.7	30	89

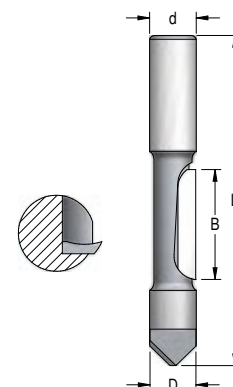

PP

Single Flute

Tool No.		D	B	L
d=6mm	d=1/4"	mm	mm	mm
PP30633	PP30634	6.3	19	63

Tool No.		D	B	L
d=3/8"	d=12mm	mm	mm	mm
PP40956		9.5	25	79
	PP51272	12.7	30	89
	PP81272	12.7	51	120
	PP81602*	16.0	51	120

*Staggered flutes

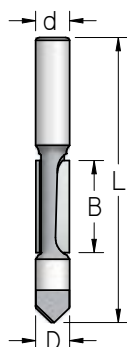
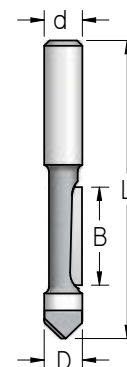

PP2

Double Flute

Tool No.		D	B	L
d=6mm	d=1/4"	mm	mm	mm
PP20633	PP20634	6.3	19	63
	PP20956	9.5	25	79
	PP21272	12.7	30	89
	PP21278	12.7	30	89
	PP28122	12.7	51	120
	PP28128	12.7	51	120

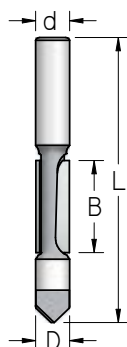

PPS

Double Sided, Staggered bit with Center Pilot.

Used for cutting out apertures in ceilings and side walls when the frame can act as a template.

Tool No.		D	B	L
d=12mm	d=1/2"	mm	mm	mm
PPS9122	PPS9128	12.7	71	107

PPT

Double Sided with 2 Pilots

Tool No.		D	B	L
d=12mm	d=1/2"	mm	mm	mm
PPT9122	PPT9128	12.7	63	126

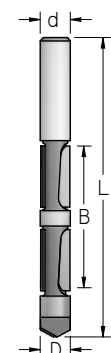
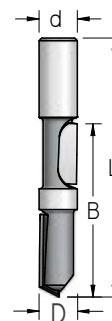

SOLID CARBIDE BITS – SINGLE FLUTE

Classic design for mass production.
Integrated Pilot (without ball bearing).

SCF

Flush Trim Laminate bits

Tool No.	D	B	L
d=6mm	d=1/4"	mm	mm
SCF1633	6.0	6	38
SCF1634	6.35	6	38
SCF2633	6.0	9.5	38
SCF2634	6.35	9.5	38

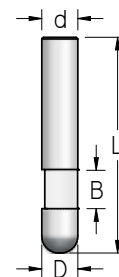

SCF...W

Double Ended Flush Trim Laminate bits.

Cost Effective.

Tool No.	D	B	L
d=1/4"	mm	mm	mm
SCF1634W	6.35	6	51

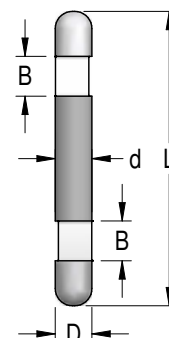

SCSL

Bevel Trim Laminate bits 7°

Tool No.	D	B	L
d=6mm	d=1/4"	mm	mm
SCSL073	SCSL074	4.8	6
			38

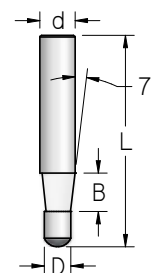
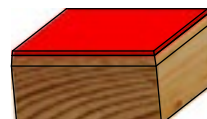

SCSL...W

Double Ended Bevel Trim Laminate bits 7°

Cost Effective.

Tool No.	D	B	L
d=1/4"	mm	mm	mm
SCSL074W	4.8	6	51

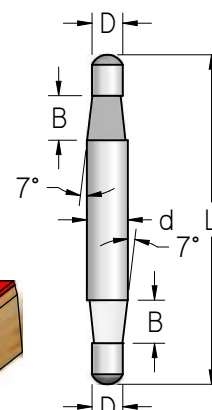

SCPP

Boring & Flush Trimmer

Tool No.	D	B	L
d=6mm	d=1/4"	mm	mm
SCPP633	6.0	6.5	40
SCPP634	6.35	6.5	38

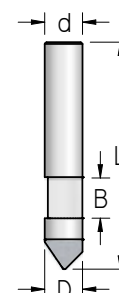

SCRB

Veining Bits

Solid Carbide, Single Flute

Tool No.		R	D	B	L
d=6mm	d=1/4"	mm	mm	mm	mm
SCRB323	SCRB324	1.6	3.2	5	38
SCRB483	SCRB484	2.4	4.8	6.5	38
	SCRB634	3.2	6.35	9	38

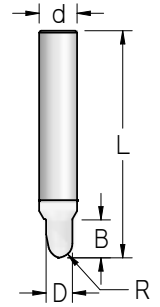

SCV

"V" Grooving Veining Bits

Solid Carbide, Single Flute

Tool No.		a	D	B	L
d=6mm	d=1/4"	degrees	mm	mm	mm
SCV6003		60	6.0	12	40
	SCV6004	60	6.35	12	38
SCV9003		90	6.0	9.5	40
	SCV9004	90	6.35	9.5	38

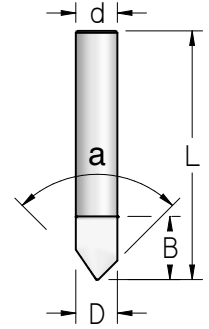

SE

Engraving Bits with Mirror Finish Carbide

For sign making and PCB milling. Used with CNC and industrial engraving machines for wood, plastic, brass, aluminum, copper and different composites.

Solid Carbide, Single Flute

Tool No.			a	D1	B	L
d=3mm	d=6mm	d=1/4"	degrees	mm	mm	mm
SE300130m			30	0.1	11	40
SE450130m			45	0.1	11	40
SE600130m			60	0.1	11	40
SE900130m			90	0.1	11	40
	SE300160m		30	0.1	14	40
	SE30013		30	0.1	14	50
	SE30023		30	0.25	14	50
	SE30053		30	0.5	14	50
	SE30103		30	1.0	14	50
	SE450160m		45	0.1	14	40
	SE600160m		60	0.1	14	40
	SE900160m		90	0.1	14	40
		SE30014X	30	0.1	14	58
		SE30024X	30	0.25	14	58
		SE30054X	30	0.5	14	58
		SE30084X	30	0.75	14	58
		SE30104X	30	1.0	14	58
		SE30154X	30	1.5	14	58
		SE30254X	30	2.5	14	58

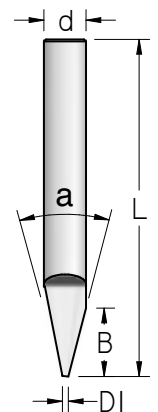

CARBIDE TIPPED "V" GROOVING BITS

V

"V" - Grooving Bits

For General Woodworking

Tool No.		a	D	B	L	
d=6mm	d=1/4"	d=8mm	degrees	mm	mm	
MV60953	MV60954		60	9.5	10	41
V601273	V601274	V601275	60	12.7	16	45
V900953	V900954	V900955	90	9.5	11	43
V901273	V901274	V901275	90	12.7	12	44
V901603	V901604		90	16.0	13	41
		V901605	90	16.0	13	45
V901903	V901904		90	19.0	16	45
		V901905	90	19.0	16	48
V902503	V902504		90	25.4	19	48
		V902505	90	25.4	19	51
V903203	V903204		90	31.8	25	55
V100323	V100324		100	31.8	21	53
V110323	V110324		110	31.8	20	51
V120323	V120324		120	31.8	18	48
V130323	V130324		130	31.8	12	45
V140323	V140324		140	31.8	12	43
V150323	V150324		150	31.8	12	42

Tool No.		a	D	B	L
d=12mm	d=1/2"	degrees	mm	mm	mm
V901272	V901278	90	12.7	12	55
V901602	V901608	90	16.0	13	51
V901902	V901908	90	19.0	16	54
V902502	V902508	90	25.4	19	57
V903202	V903208	90	31.8	25	63
V903802	V903808	90	38.1	32	70
V100322	V100328	100	31.8	21	70
V110322	V110328	110	31.8	20	70
V120322	V120328	120	31.8	18	70
V150322	V150328	150	31.8	12	70

VE

"V"-Grooving for Shaping Panels

Designed for folding and shaping Aluminum Composite cladding Materials Such as Alucobond, Dibond etc. Routing V-shaped grooves into the aluminum cover and part of the polyethylene core, allows folding the remaining material by hand.

Tool No.		a	b	D	D1	B	L	
d=6mm	d=1/4"	d=8mm	degrees	degrees	mm	mm	mm	
VE90123	VE90124		90	90	13.0	3	12.5	57
		VE90125	90	90	13.0	2.4	12.5	57
VE13503	VE13504	VE13505	135	45	18.0	2	15.5	57

Tool No.		a	b	D	D1	B	L
d=12mm	d=1/2"	degrees	degrees	mm	mm	mm	mm
VE13512	VE13518	135	45	19.0	2	9.5	63

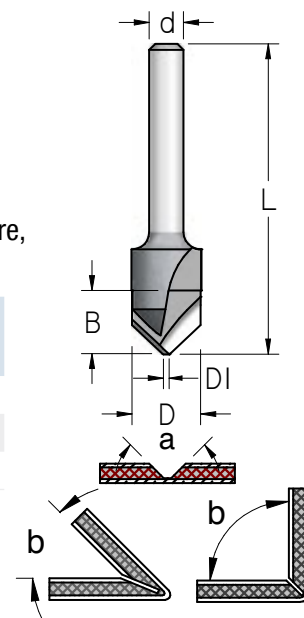
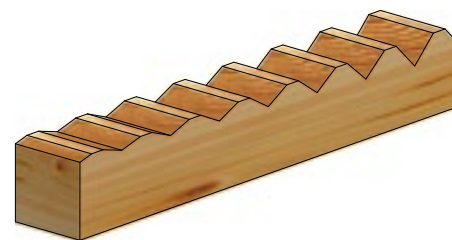
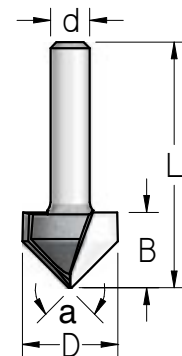

VG

Gypsum plasterboard "V" grooving bits

Cuts grooves for folding. The plasterboard cover is not cut through, allowing the corner to be folded.

	Tool No.		a	D	B	L	
	d=6mm	d=1/4"	d=8mm	degrees	mm	mm	
	VG90273	VG90274	VG90275	90	26.0	12.7	50

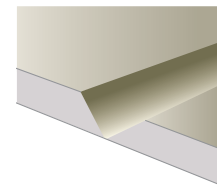

After Folding

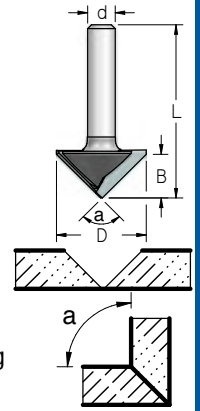

Z

Dovetail Bits

	Tool No.		a	D	B	L	
	d=6mm	d=1/4"	d=8mm	degrees	mm	mm	
	Z100903	Z100904	Z100905	9	9.5	9.5	41
	Z131403	Z131404	Z131405	14	12.7	12.5	49

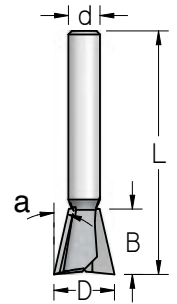
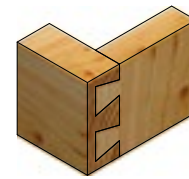

	Tool No.		a	D	B	L
	d=12mm	d=1/2"	degrees	mm	mm	mm
	Z072202	Z072208	7	22.0	22	60
	Z100902	Z100908	9	9.5	9.5	54
	Z131402	Z131408	14	12.7	12.5	54
	Z142542	Z142548	14	25.4	25	69.5

Z

Dovetail Bits, with relieving teeth

	Tool No.		a	D	B	L
	d=6mm	d=1/4"	degrees	mm	mm	mm
	Z141403	Z141404	14	12.7	13	49

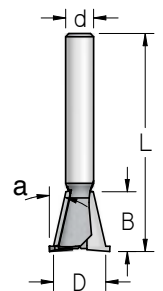
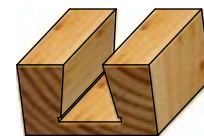

ZB

Brookman Dovetail Bits

For Brookman Machines

Tool No.	a	D	B	L
	degrees	mm	mm	mm
ZB13146	10	14.3	12.7	38

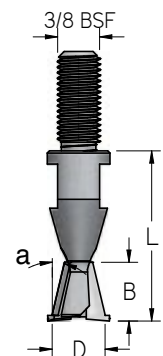
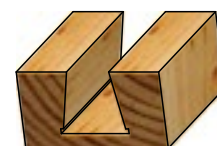

RU

Panel and Veining Bits

Tool No.	R	D	D1	B	L	
d=6mm	d=1/4"	mm	mm	mm	mm	
Solid Carbide Single Flute						
SCRU244	2.4	5.0	0.5	6.3	51	
SCRU324	3.2	6.3	0.5	7	51	
Carbide Tipped 2 Flutes						
RU05003	RU05004	4.8	9.5	0.7	9	47
RU06003	RU06004	6.2	13.0	0.7	13	51
RU07003	RU07004	7.5	14.5	0.7	15	55
RU09003	RU09004	9.5	19.0	1.1	18	51

Tool No.	R	D	D1	B	L	
d=12mm	d=1/2"	mm	mm	mm	mm	
RU05002	RU05008	4.8	9.5	0.7	9	54
RU09002	RU09008	9.5	19.0	1.1	18	57

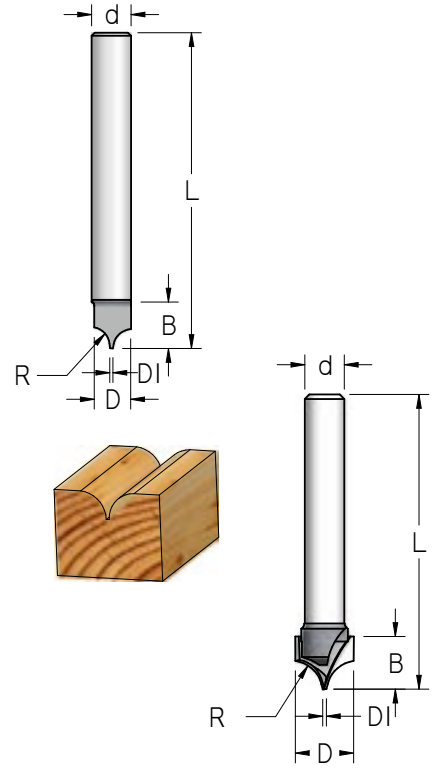

RB

Classical Core Box bits

d=6mm	Tool No.	d=8mm	R	D	B	L
d=6mm	d=1/4"	d=8mm	mm	mm	mm	mm
RB06003	RB06004	RB06005	3.2	6.3	5.5	42
RB08003	RB08004	RB08005	4.0	8.0	6	38
RB10003	RB10004		4.8	9.5	6	38
		RB10005	4.8	9.5	6	42
RB12003	RB12004	RB12005	6.3	12.7	9	41
RB16003	RB16004	RB16005	8.0	16.0	9.5	43
RB19003	RB19004	RB19005	9.5	19.0	11	44
RB22003	RB22004		11.1	22.2	14	46
		RB22005	11.1	22.2	14	43
RB25003	RB25004		12.7	25.4	16	48
		RB25005	12.7	25.4	16	50

Tool No.	R	D	B	L	
d=12mm	d=1/2"	mm	mm	mm	
RB10002	RB10008	4.8	9.5	6	51
RB12002	RB12008	6.3	12.7	9	54
RB16002	RB16008	8.0	16.0	9.5	51
RB19002	RB19008	9.5	19.0	11	52
RB22002	RB22008	11.1	22.2	14	57
RB25002	RB25008	12.7	25.4	16	60

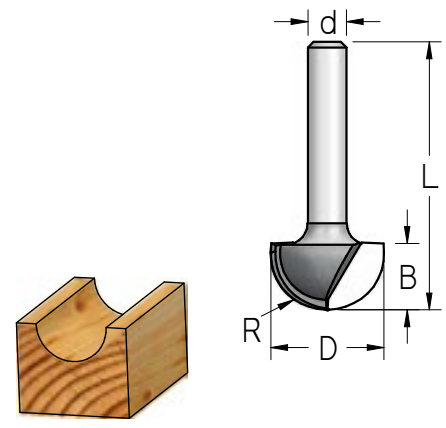

DB

Core Box Template Bits

With Ball Bearing Guide.

Tool No.		R	D	B	L	Ball Bearing	Retaining Collar
d=6mm	d=1/4"	mm	mm	mm	mm		
DB12003	DB12004	6.3	12.7	9	50	B127063	PF06300
DB16003	DB16004	8.0	16.0	9	52	B159063	PF06300
DB19003	DB19004	9.5	19.0	11	53	B190063	PF06300

Tool No.		R	D	B	L	Ball Bearing	Retaining Collar
d=12mm	d=1/2"	mm	mm	mm	mm		
DB19002	DB19008	9.5	19.0	11	83	B190127 x2	PF19000
DB25002	DB25008	12.7	25.4	16	83	B254127	PF19000

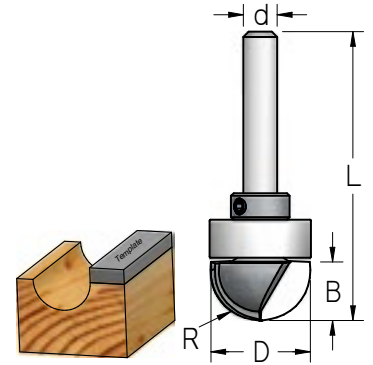

RBL

Core Box Bits - Extra Deep

Tool No.		R	D	B	L	
d=6mm	d=1/4"	d=8mm	mm	mm	mm	
RBL0323	RBL0324	RBL0325	1.6	3.2	9.5	44
RBL0483	RBL0484	RBL0485	2.4	4.8	13	47
RBL0633	RBL0634	RBL0635	3.2	6.3	13	47
RBL0803	RBL0804		4.0	8.0	13	47
		RBL0805	4.0	8.0	13	50

Tool No.		R	D	B	L
d=12mm	d=1/2"	mm	mm	mm	mm
RBL1002	RBL1008	4.8	9.5	25	70
RBL1272	RBL1278	6.3	12.7	32	73
RBL1402	RBL1408	7.1	14.2	32	73
RBL1602	RBL1608	7.9	16.0	32	70
RBL1902	RBL1908	9.5	19.0	32	70
RBL2202	RBL2208	11.1	22.2	32	70
RBL2502	RBL2508	12.7	25.4	32	70

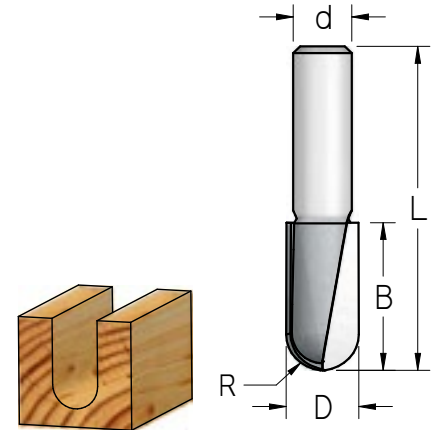

RV

Plunging Rounding Over Bits

Tool No.		R	D	D1	B	L	
d=6mm	d=1/4"	d=8mm	mm	mm	mm	mm	
RV06003	RV06004	RV06005	6.3	19.0	6.3	13	41
RV08003	RV08004	RV08005	8.0	22.2	6.3	14	43
RV10003	RV10004	RV10005	9.5	25.4	6.3	16	44
		RV12005	12.7	35.0	9.5	25	57

Tool No.		R	D	D1	B	L
d=12mm	d=1/2"	mm	mm	mm	mm	mm
RV06002	RV06008	6.3	19.0	6.3	13	51
RV08002	RV08008	8.0	22.2	6.3	14	52
RV10002	RV10008	9.5	25.4	6.3	16	54
RV12002	RV12008	12.7	35.0	9.5	25	63
RV16002	RV16008	16.0	44.5	12.7	32	70
RV19002	RV19008	19.0	50.8	12.7	38	75

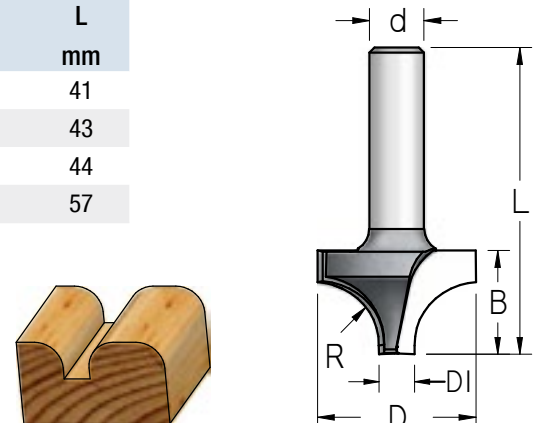

RH

Plunging Beading & Rounding Over Bits

Tool No.		R=B1	D	D1	B	L
d=6mm	d=1/4"	mm	mm	mm	mm	mm
RH03003	RH03004	3.2	9.5	3.3	7	48
RH05003	RH05004	4.8	13.5	4.0	9.5	41
RH06003	RH06004	6.3	17.5	4.8	13	44
RH08003	RH08004	8.0	22.2	6.3	14	46
RH10003	RH10004	9.5	25.4	6.3	16	46
RH12003	RH12004	12.7	31.8	6.3	17	49

Tool No.		R=B1	D	D1	B	L
d=12mm	d=1/2"	mm	mm	mm	mm	mm
RH06002	RH06008	6.3	17.5	4.8	13	54
RH08002	RH08008	8.0	22.2	6.3	14	56
RH10002	RH10008	9.5	25.4	6.3	16	56
RH12002	RH12008	12.7	31.8	6.3	17	59

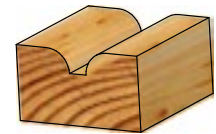
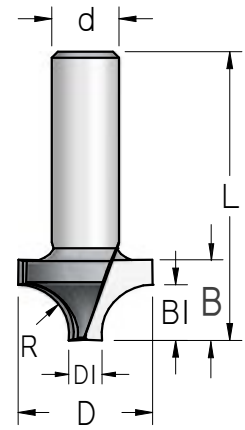

RC

Plunging Classical Bits

Tool No.		R	R1	D	B	L	
d=6mm	d=1/4"	d=8mm	mm	mm	mm	mm	
MRC0303	MRC0304		4.0	3.2	12.7	8	38
RC03003	RC03004	RC03005	2.4	3.5	12.7	9	51
RC05003	RC05004	RC05005	3.6	5.0	19.0	13	52
RC06003	RC06004	RC06005	5.0	6.3	25.4	16	55

Tool No.		R	R1	D	B	L
d=12mm	d=1/2"	mm	mm	mm	mm	mm
RC05002	RC05008	3.6	5.0	19.0	13	69
RC06002	RC06008	5.0	6.3	25.4	16	73
RC10002	RC10008	7.0	10.0	35.0	15	65

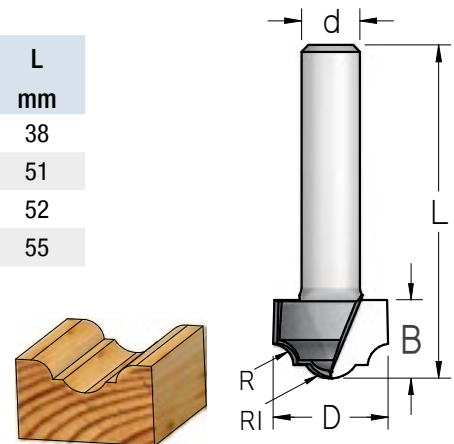

DC

Classical Template Bits

With Ball Bearing Guide.

Tool No.		R	R1	D	B	L	Ball Bearing	Retaining Collar
d=6mm	d=1/4"	d=8mm	mm	mm	mm	mm		
DC03003	DC03004		2.4	3.5	12.7	9	B127063	PF06300
DC05003	DC05004	DC05005	3.6	5.0	19.0	13	B190080	PF08000
DC06003	DC06004		5.0	6.3	25.4	16	B254127	PF19000

Tool No.		R	R1	D	B	L	Ball Bearing	Retaining Collar
d=12mm	d=1/2"	mm	mm	mm	mm	mm		
DC06002	DC06008	3.2	3.2	25.4	16	73	B254127	PF19000
DC10002	DC10008	3.2	5.0	35.0	15	73	B350150	PF12700

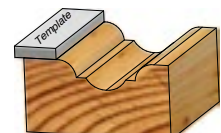
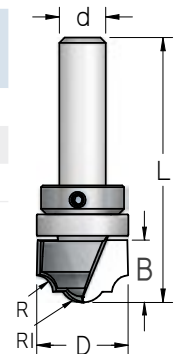

DM

Panelling Flat Bottom Groover

With Ball Bearing Guide.

Tool No.		R=R1	D	D1	B	L	Ball Bearing	Retaining Collar
d=12mm	d=1/2"	mm	mm	mm	mm	mm		
DM35002	DM35008	5.5	35.0	12.7	14	66	B350150	PF12700

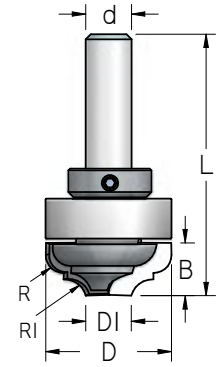
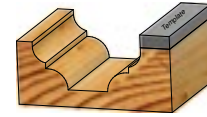

RA, RRA

Ogee Bits

d=6mm	Tool No.		R=R1	D	D1	B	L
d=1/4"	d=8mm	mm	mm	mm	mm	mm	mm
RA20003	RA20004		2	12.7	4.7	8	51
		RA20005	2	12.7	4.7	8	54
RA30003	RA30004	RA30005	3.2	19.0	6.4	13	54
RRA2503	RRA2504	RRA2505	3.2	25.4	10.0	9.5	50

Tool No.		R=R1	D	D1	B	L
d=12mm	d=1/2"	mm	mm	mm	mm	mm
RA30002	RA30008	3.2	19.0	6.4	13	64
RRA2502	RRA2508	3.2	25.4	10.0	9.5	60
RRA3502	RRA3508	3.2	35.0	12.7	9.5	59

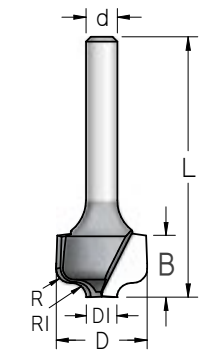
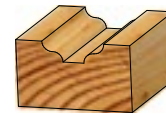

RRC

Plunge Ogee Bits

d=6mm	Tool No.		R	R1	D	B	L
d=1/4"	d=8mm	mm	mm	mm	mm	mm	mm
MRR1203	MRR1204	MRR1205	3	3	12.7	8	38
RRC2703	RRC2704	RRC2705	6	5	27.0	12	52

Tool No.		R	R1	D	B	L
d=12mm	d=1/2"	mm	mm	mm	mm	mm
RRC2702	RRC2708	6	5	27.0	12	57

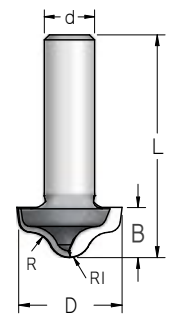
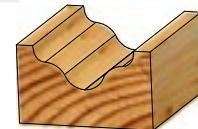

RR

Plunging Double Rounding Over Bits

Tool No.		R	D	D1	B	L
d=6mm	d=1/4"	mm	mm	mm	mm	mm
RR42543	RR42544	4.5	25.4	10.0	16	44

Tool No.		R	D	D1	B	L
d=12mm	d=1/2"	mm	mm	mm	mm	mm
RR42542	RR42548	4.5	25.4	10.0	16	67

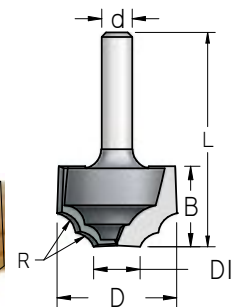
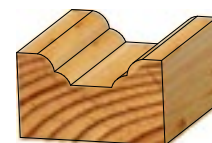

DL

Plunging Classical Template Bits

With Ball Bearing Guide

Tool No.		R	D	D1	B	L	Ball Bearing	Retaining Collar
d=6mm	d=1/4"	mm	mm	mm	mm	mm		
DL42543	DL42544	4.5	25.4	10.0	16	61	B260100	PF06300

Tool No.		R	D	D1	B	L	Ball Bearing	Retaining Collar
d=12mm	d=1/2"	mm	mm	mm	mm	mm		
DL42542	DL42548	4.5	25.4	10.0	16	67	B254127	PF19000

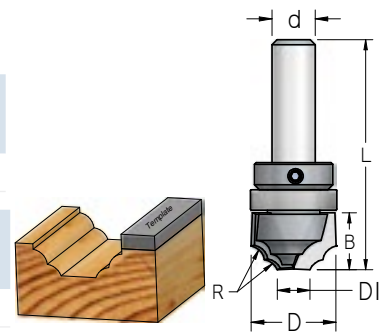

RR

Plunging Classical Bit Shallow Groove

With Carbide Plunging Tip.

Tool No.		D	D1	B	L
d=12mm	d=1/2"	mm	mm	mm	mm
RR32002	RR32008	31.8	12.5	11	61

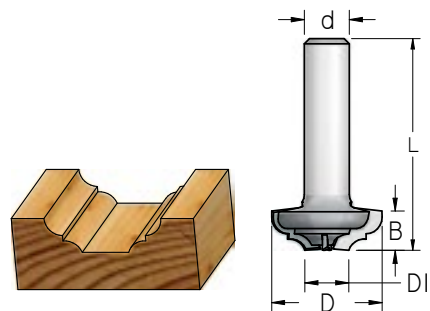

RRI

Plunging Classical Bit Shallow Groove

Tool No.		R	D	B	L
d=12mm	d=1/2"	mm	mm	mm	mm
RRI0502	RRI0508	9.0	36.5	9.5	61

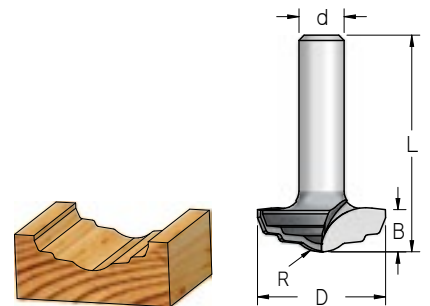

MM

Key Hole Bits - Single Flute

For "Key Hole" slots in picture frames.

Tool No.		D	D1	B	B1	L	
d=6mm	d=1/4"	d=8mm	mm	mm	mm	mm	
MM10953	MM10954	MM10955	9.5	4.8	9.5	4.8	40
MM12953	MM12954	MM12955	12.7	8.0	9.5	4.8	41

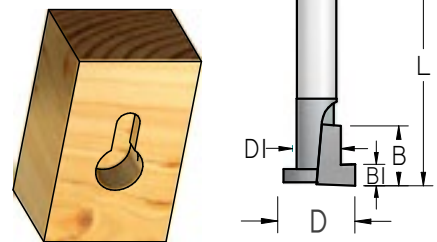

MM

T-Slot Bits

Tool No.		D	D1	B	B1	L
d=12mm	d=1/2"	mm	mm	mm	mm	mm
MM28202	MM28208	28.0	9.5	20.7	8	60
MM35222	MM35228	35.0	12.7	22.2	9.5	65

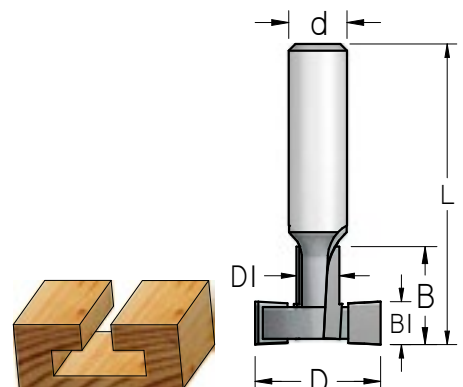

RS

Roman Ogee Stepped Bits

With Ball Bearing Guide.

d=6mm	Tool No.		R	D	B	L	Ball Bearing
	d=1/4"	d=8mm	mm	mm	mm	mm	
MRS0303	MRS0304		3.0	20.0	10	47	B080040
RS04003	RS04004	RS04005	4.0	25.4	14.5	53	B095048
RS06003	RS06004	RS06005	6.3	35.0	19	59	B095048

Tool No.		R	D	B	L	Ball Bearing
d=12mm	d=1/2"	mm	mm	mm	mm	
RS04002	RS04008	4.0	25.4	14.5	63	B095048
RS06002	RS06008	6.3	35.0	19	69	B095048

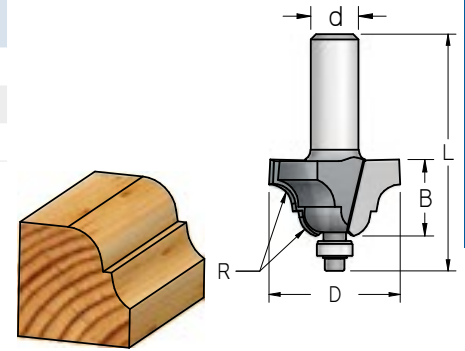

RD

Roman Ogee Bits

With Ball Bearing Guide.

Tool No.		R	D	B	L	Ball Bearing
d=6mm	d=1/4"	mm	mm	mm	mm	
Nano Ogee Bits with Miniature Bearing						
RD00253	RD00254	2.4	14.3	8	47	B048024

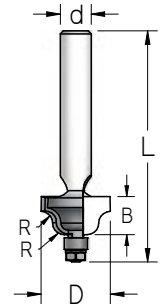

d=6mm	Tool No.		R	D	B	L	Ball Bearing
	d=1/4"	d=8mm	mm	mm	mm	mm	
MRD0303	MRD0304		3.0	20.0	10	47	B080040
RD04003	RD04004		4.0	25.4	14.5	53	B095032
		RD04005	4.0	25.4	14.5	53	B095048
RD06003	RD06004	RD06005	6.3	35.0	19	59	B095032

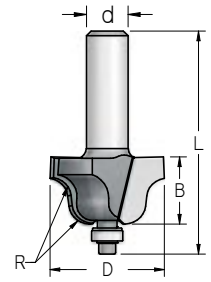

Tool No.		R	D	B	L	Ball Bearing
d=12mm	d=1/2"	mm	mm	mm	mm	
RD04002	RD04008	4.0	25.4	14.5	63	B095032
RD06002	RD06008	6.3	35.0	19	69	B095032

RJ

Wavy Edge Bits

With Ball Bearing Guide.

d=6mm	Tool No.		R	D	B	L	Ball Bearing
	d=1/4"	d=8mm	mm	mm	mm	mm	
MRJ0303	MRJ0304		2.5	20.0	10	47	B080040
RJ04003	RJ04004		4.0	31.8	17.5	57	B127048

Tool No.		R	D	B	L	Ball Bearing
d=12mm	d=1/2"	mm	mm	mm	mm	
RJ04002	RJ04008	4.0	31.8	17.5	71	B127048

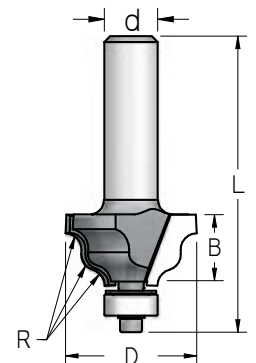
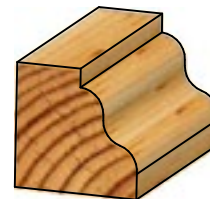

RT

Ogee Bits

With Ball Bearing Guide.

Tool No.		R	R1	D	B	L	Ball Bearing	
d=6mm	d=1/4"	d=8mm	mm	mm	mm	mm		
RT06003	RT06004	RT06005	6	5	35.0	17	58	B127048

Tool No.		R	R1	D	B	L	Ball Bearing
d=12mm	d=1/2"	mm	mm	mm	mm	mm	
RT06002	RT06008	6	5	35.0	17	68	B127048

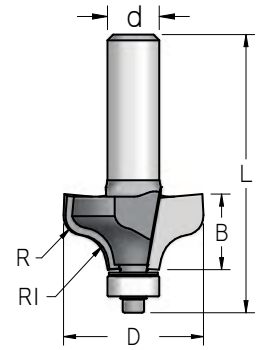

RM

Classical Cove and Bead Bits

With Ball Bearing Guide

Tool No.		R	R1	D	B	L	Ball Bearing	
d=6mm	d=1/4"	d=8mm	mm	mm	mm	mm		
MRM0303	MRM0304		3.0	3.0	20.0	10	47	B080040
RM04003	RM04004	RM04005	4.0	4.0	28.6	13	53	B127048
RM06003	RM06004		6.3	5.0	35.0	17	58	B127048

Tool No.		R	R1	D	B	L	Ball Bearing
d=12mm	d=1/2"	mm	mm	mm	mm	mm	
RM04002	RM04008	4.0	4.0	28.6	13	65	B127048
RM06002	RM06008	6.3	5.0	35.0	17	71	B127048

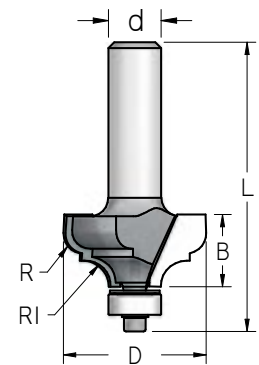

RZ

Cove Bits

With Ball Bearing Guide

Tool No.		R	D	B	L	Ball Bearing	
d=6mm	d=1/4"	d=8mm	mm	mm	mm		
MRZ0303	MRZ0304		3.0	14.0	10	47	B080040
M07RZ63	M07RZ64		6.0	20.0	10	47	B080040
RZ06003	RZ06004	RZ06005	6.3	22.2	12	52	B095032
RZ08003	RZ08004	RZ08005	8.0	25.4	12	51	B095032
RZ10003	RZ10004	RZ10005	9.5	28.6	14	55	B095032
RZ12003	RZ12004	RZ12005	12.7	35.0	16	57	B095032

Tool No.		R	D	B	L	Ball Bearing
d=12mm	d=1/2"	mm	mm	mm	mm	
RZ06002	RZ06008	6.3	22.2	12	64	B095032
RZ08002	RZ08008	8.0	25.4	12	63	B095032
RZ10002	RZ10008	9.5	28.6	14	65	B095032
RZ12002	RZ12008	12.7	35.0	16	66	B095032

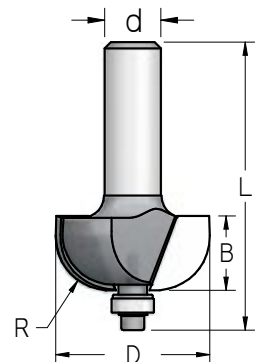

RN

Classical Bits

With Ball Bearing Guide

d=6mm	Tool No.		R	R1	D	B	L	Ball Bearing
	d=1/4"	d=8mm	mm	mm	mm	mm	mm	
RN03003	RN03004	RN03005	5.0	6.0	31.8	13	52	B127048
RN04003	RN04004	RN04005	6.5	8.5	38.1	16	56	B127048

d=12mm	Tool No.		R	R1	D	B	L	Ball Bearing
	d=1/2"		mm	mm	mm	mm	mm	
RN03002	RN03008		5.0	6.0	31.8	13	62	B127048
RN04002	RN04008		6.5	8.5	38.1	16	68	B127048

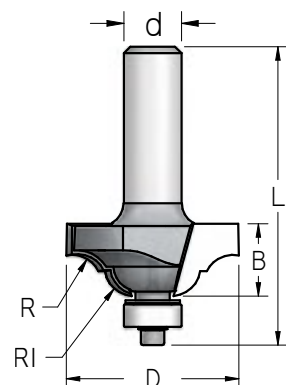

RL

Double Rounding Over Bits

With Ball Bearing Guide

d=6mm	Tool No.		R	D	B	L	Ball Bearing
	d=1/4"	d=8mm	mm	mm	mm	mm	
RL04003	RL04004	RL04005	4.0	28.6	13	52	B127048
RL06003	RL06004	RL06005	5.5	35.0	17	58	B127048

d=12mm	Tool No.		R	D	B	L	Ball Bearing
	d=1/2"		mm	mm	mm	mm	
RL04002	RL04008		4.0	28.6	13	63	B127048
RL06002	RL06008		5.5	35.0	17	68	B127048

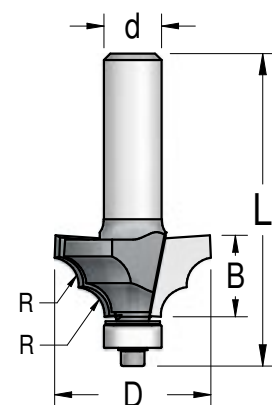
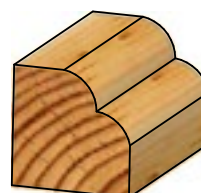

RP

Beading Bits

With Ball Bearing Guide.

d=6mm	Tool No.		R	D	D1	B	L	Ball Bearing
	d=1/4"	d=8mm	mm	mm	mm	mm	mm	
RP05003	RP05004	RP05005	4.8	22.2	12.7	11	50	B095048
RP06003	RP06004	RP06005	6.3	25.4	12.7	11	50	B095048
RP10003	RP10004	RP10005	9.5	31.8	12.7	16	54	B095048
RP12003	RP12004	RP12005	12.7	38.1	12.7	18	59	B095048

d=12mm	Tool No.		R	D	D1	B	L	Ball Bearing
	d=1/2"		mm	mm	mm	mm	mm	
RP06002	RP06008		6.3	25.4	12.7	11	61	B095048
RP10002	RP10008		9.5	31.8	12.7	16	68	B095048
RP12002	RP12008		12.7	38.1	12.7	18	68	B095048
RP16002	RP16008		16.0	44.5	12.7	22	76	B095048
RP19002	RP19008		19.0	50.8	12.7	25	78	B095048

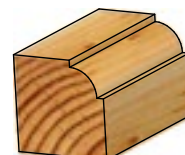
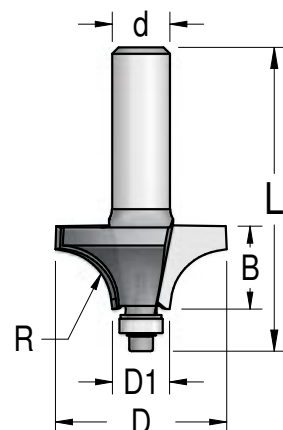

RW**Rounding Over Bits**

Extended line for wide range of applications.
Smaller bearings allow working in tight spaces.

Tool No.		R	D	D1	B	L	Ball Bearing
d=6mm	d=1/4"	mm	mm	mm	mm	mm	
Nano Rounding Over Bits							
RW00163	RW00164	1.6	8	4.8	8	47	B048024
RW00243	RW00244	2.4	9.5	4.8	9.5	47	B048024
RW00323	RW00324	3.2	11.1	4.8	9.5	47	B048024
RW00403	RW00404	4.0	12.7	4.8	9.5	47	B048024
RW00483	RW00484	4.8	14.3	4.8	8.5	47	B048024

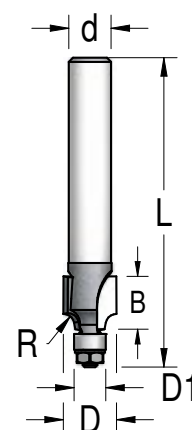

Tool No.		R	D	D1	B	L	Ball Bearing	
d=6mm	d=1/4"	d=8mm	mm	mm	mm	mm		
RW60603	RW60604		6.3	19.0	6.3	6.8	47	B063032
RW61003	RW61004		9.5	25.4	6.3	10	52	B063032

MRW0303	MRW0304		3.0	14.2	8.0	11	47	B080040
M12RW63	M12RW64		6.0	21.0	8.0	10	47	B080040
RW90603	RW90604		6.3	22.2	9.5	7	50	B095032
RW91003	RW91004		9.5	28.6	9.5	10	54	B095032

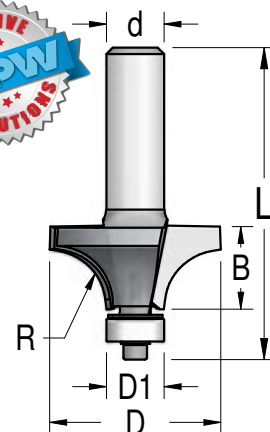

RW01603	RW01604	RW01605	1.6	15.9	12.7	8	48	B127048
RW02003	RW02004	RW02005	2.0	16.7	12.7	8	48	B127048
RW03003	RW03004	RW03005	3.2	19.0	12.7	9.5	48	B127048
RW04003	RW04004	RW04005	4.0	20.6	12.7	9.5	50	B127048
RW05003	RW05004	RW05005	4.8	22.2	12.7	11	50	B127048
RW06003	RW06004	RW06005	6.3	25.4	12.7	11	50	B127048
RW08003	RW08004	RW08005	8.0	28.6	12.7	13.5	53	B127048
RW10003	RW10004	RW10005	9.5	31.8	12.7	16	54	B127048
RW12003	RW12004	RW12005	12.7	38.1	12.7	18	59	B127048
		RW15005	15.0	42.5	12.7	22	64	B127048



Tool No.		R	D	D1	B	L	Ball Bearing
d=12mm	d=1/2"	mm	mm	mm	mm	mm	
RW03002	RW03008	3.2	19.0	12.7	9.5	61	B127048
RW04002	RW04008	4.0	20.6	12.7	9.5	59	B127048
RW05002	RW05008	4.8	22.2	12.7	11	62	B127048
RW06002	RW06008	6.3	25.4	12.7	11	61	B127048
RW08002	RW08008	8.0	28.6	12.7	13.5	67	B127048
RW10002	RW10008	9.5	31.8	12.7	16	68	B127048
RW12002	RW12008	12.7	38.1	12.7	18	68	B127048
RW16002	RW16008	16.0	44.5	12.7	22	76	B127048
RW19002	RW19008	19.0	50.8	12.7	25	78	B127048
RW22002	RW22008	22.2	57.1	12.7	30	79	B127048
RW25002	RW25008	25.4	63.5	12.7	32	85	B127048
*RW32002	*RW32008	31.8	76.3	12.7	38	98	B127048
**RW38002	**RW38008	38.1	88.9	12.7	44	105	B127048

*Max speed 18000 RPM **Max speed 16000 RPM

RWG

4 Flutes Rounding Over Bits

With Ball Bearing Guide.

For better surface finish and longer tool life.



Tool No.		R	D	D1	B	L	Ball Bearing
d=6mm	d=1/4"	mm	mm	mm	mm	mm	
RWG0503	RWG0504	4.8	25.4	15.9	11	49	B160048
RWG0603	RWG0604	6.3	28.6	15.9	11	51	B160048
RWG1003	RWG1004	9.5	35.0	15.9	16	53	B160048
RWG1203	RWG1204	12.7	41.3	15.9	18	58	B160048

Tool No.		R	D	D1	B	L	Ball Bearing
d=12mm	d=1/2"	mm	mm	mm	mm	mm	
RWG0502	RWG0508	4.8	25.4	15.9	11	62	B160048
RWG0602	RWG0608	6.3	28.6	15.9	11	63	B160048
RWG1002	RWG1008	9.5	35.0	15.9	16	66	B160048
RWG1202	RWG1208	12.7	41.3	15.9	18	68	B160048

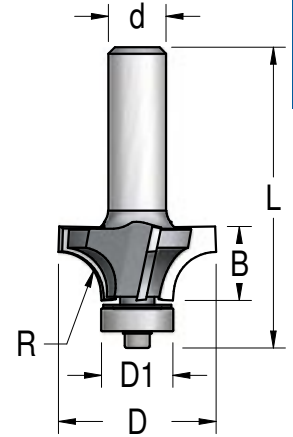

RWB

Laminate Rounding Over Bits

With 2 Ball Bearing Guides for added stability

Used especially for smoothing sharp corners of edge banded laminates.

Special design to avoid damaging the panel while doing this delicate job.

Tool No.			R	D	D1	B	L	Ball Bearing
d=6mm	d=1/4"	d=8mm	mm	mm	mm	mm	mm	
RWB0133	RWB0134	RWB0135	1.3	16.5	12.7	8	57	B127048 x2
RWB0203	RWB0204	RWB0205	2.0	18	12.7	8	57	B127048 x2
RWB0303	RWB0304	RWB0305	3.0	20	12.7	9.5	59	B127048 x2

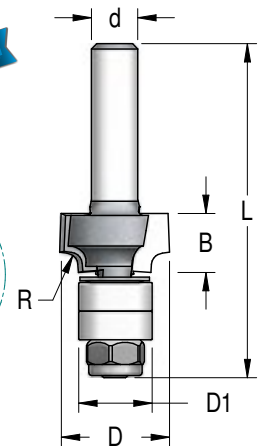
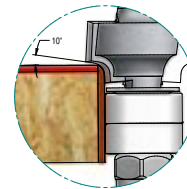

RF

Bull Nose Bits

Tool No.		R	D	B	L
d=6mm	d=1/4"	d=8mm	mm	mm	mm
RF02003	RF02004		2.0	13.5	41
RF02803	RF02804		2.8	15.1	41
		RF02805	2.8	15.1	45
RF03603	RF03604		3.6	16.7	47
		RF03605	3.6	16.7	51
RF05203	RF05204		5.2	22.2	47
		RF05205	5.2	22.2	51

Tool No.		R	D	B	L
d=12mm	d=1/2"	mm	mm	mm	mm
RF05202	RF05208	5.2	22.2	19	57
RF09502	RF09508	9.5	33.3	35	72
RF12702	RF12708	12.7	42.0	40	78

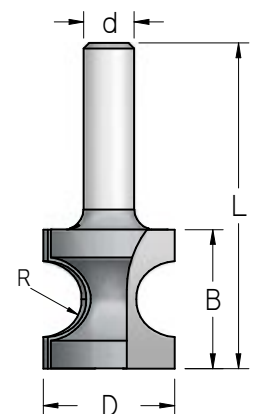

RF

Bull Nose Bits

With Ball Bearing Guide.

Tool No.		R	D	B	L	Ball Bearing
d=12mm	d=1/2"	mm	mm	mm	mm	
RF06812	RF06818	6.8	26.2	26	75	B127048
RF12712	RF12718	12.7	44.5	40	93	B190063
RF15912	RF15918	15.9	50.8	50	103	B190063

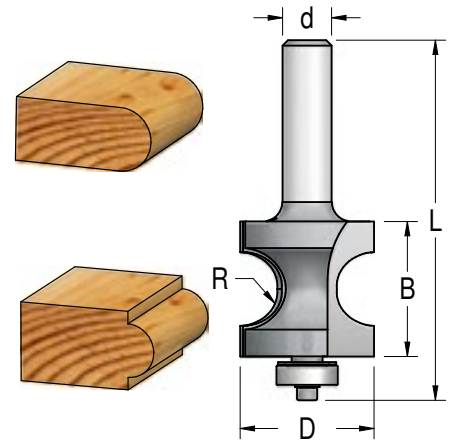

RO

Finger Grip Bits – Trapezoidal

Tool No.		D	D1	B	B1	L
d=12mm	d=1/2"	mm	mm	mm	mm	mm
R045002	R045008	45	25	21	8	61

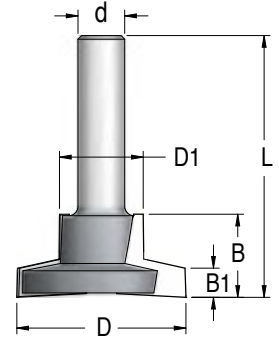
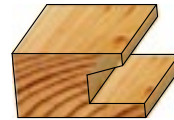

RO

Finger Grip Bits – Short cut

Tool No.		D	R	B	L
d=6mm	d=1/4"	mm	mm	mm	mm
R010003	R010004	26	9.5	9.5	42

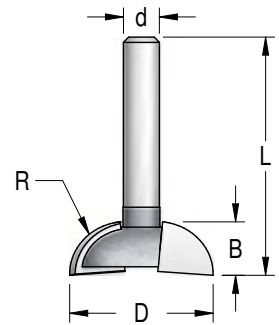

RO

Classic Finger Grip Bits

Tool No.		C	D	R	R1	B	L
d=12mm	d=1/2"	mm	mm	mm	mm	mm	mm
R019002	R019008	4.5	19	4.8	2.3	14.3	57.5
R029002	R029008	9	29	4.8	2.3	14	60
R070002	R070008	8.0	31.8	4.8	2.5	12	70
R038002	R038008	10.5	38.0	5.5	2.0	14.5	59

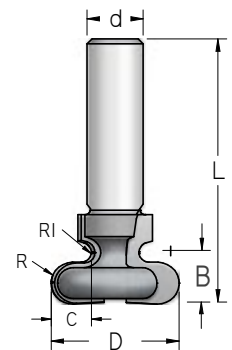
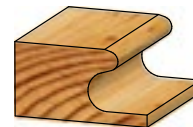

RO

Finger Grip Bits

With Ball Bearing Guide.

Tool No.		C	D	R	R1	B	L	Ball Bearing
d=12mm	d=1/2"	mm	mm	mm	mm	mm	mm	
R070012	R070018	8	44.0	5.0	2.5	12	76	B127063

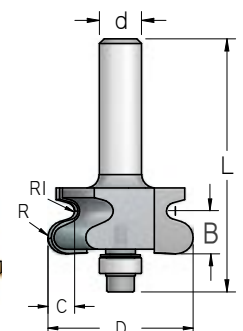



RK04

Chamfering Bit with Radius

Tool No.		A	a	R	D	B	L	Ball Bearing
d=12mm	d=1/2"	mm	degrees	mm	mm	mm	mm	
RK04102	RK04108	24	10	4.0	61	14	78	B127048

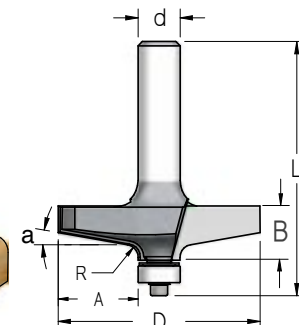

RK

Ogee

Tool No.		A	D	B	L	Ball Bearing
d=12mm	d=1/2"	mm	mm	mm	mm	
RK17002	RK17008	27.0	66.7	16	67.5	B127048
*RK18002	*RK18008	36.5	85.7	16	75	B127048

*Max speed 16000 RPM

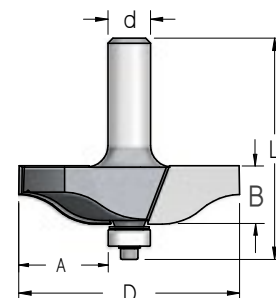
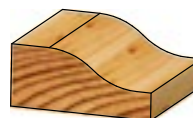

RK15

Traditional

Tool No.		A	a	D	B	L	Ball Bearing
d=12mm	d=1/2"	mm	degrees	mm	mm	mm	
*RK15002	*RK15008	36.5	15	85.7	12.7	71	B127048

*Max speed 16000 RPM

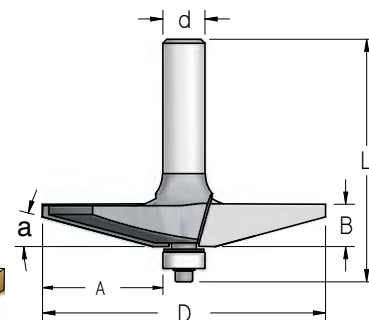

RK20

Traditional

Tool No.		A	a	D	B	L	Ball Bearing
d=12mm	d=1/2"	mm	degrees	mm	mm	mm	
RK20002	RK20008	27	20	66.7	16	69	B127048

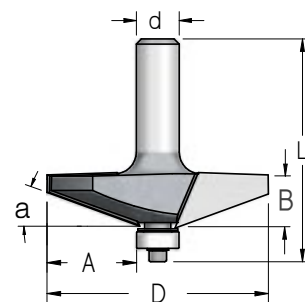
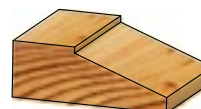

RK40

Cove

Tool No.		A	R	D	B	L	Ball Bearing
d=12mm	d=1/2"	mm	mm	mm	mm	mm	
*RK40002	*RK40008	36.5	40	85.8	12.7	72	B127048

*Max. Speed 16000 RPM

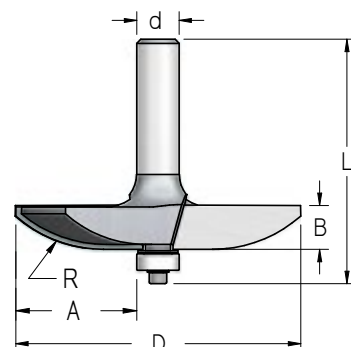

RK43

Raised Panel Thumbnail Bits



Tool No.		A	R	D	B	L	Ball Bearing
d=12mm	d=1/2"	mm	mm	mm	mm	mm	
*RK43002	*RK43008	28.2	43	69.2	16	76	B127048

*Max. Speed 18000 RPM

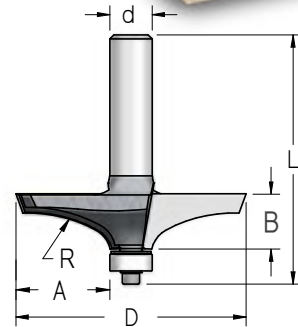

Tongue & Groove Easy Set For Profile Scribed Doors

Assembly with 2 ball bearing guides and 3 grooving cutters.

No reassembly required.

Both parts of the joint are cut by only changing the cutter height.

RGD2

Ogee

Description	Tool No.			D	B	B1	L
	d=8mm	d=12mm	d=1/2"				
Assembly	RGD2005	RGD2002	RGD2008	41.0	22.0		84
Components							
1. Profile cutter	RGD2000	RGD2000	RGD2000	41.0		6.3	
2. Cutter	NG41060	NG41060	NG41060	41.0		6.3	
Ball Bearing	B220080	B220080	B220080				
Arbor & Nut	NHRG825	NHRG822	NHRG828				

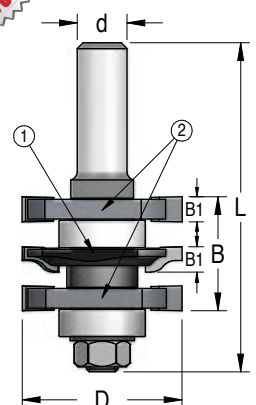
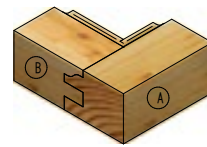
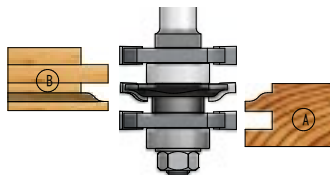

RGD5

Traditional

Description	Tool No.			D	B	B1	L
	d=8mm	d=12mm	d=1/2"				
Assembly	RGD5005	RGD5002	RGD5008	41.0	22.0		84
Components:							
1. Profile cutter	RGD5000	RGD5000	RGD5000	41.0		6.3	
2. Cutter	NG41060	NG41060	NG41060	41.0		6.3	
Ball Bearing	B220080	B220080	B220080				
Arbor & Nut	NHRG825	NHRG822	NHRG828				

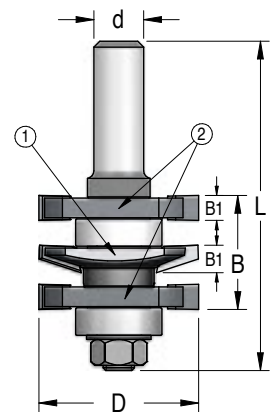
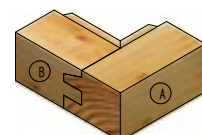
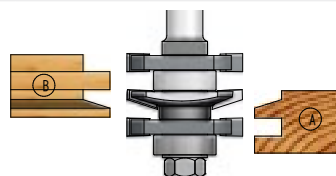

TONGUE & GROOVE CLASSIC SETS

Assembly with Ball Bearing Guide.

By reversing the assembly, you can use a single tool for both cuts A & B.
Shims should be used for perfect alignment before and after sharpening.

RG1

Ogee

Description	Tool No.			D	B	B1	B2	L
	d=8mm	d=12mm	d=1/2"					
Assembly	RG10005			46.0	22.0			70
		RG10002	RG10008	46.0	22.0			76
Components								
1. Profile cutter	RG10000	RG10000	RG10000	46.0			15	
2. Cutter	NG46040	NG46040	NG46040	46.0		4		
Ball Bearing	B220080	B220080	B220080					
Arbor & Nut	NG00005	NG00002	NG00008					

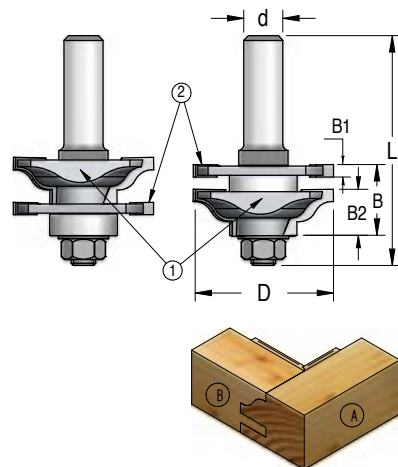
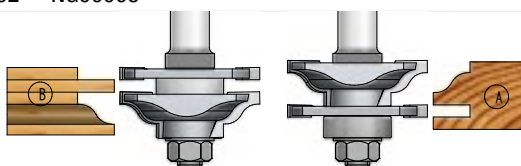

RG2

Ogee

Description	Tool No.			D	B	B1	B2	L
	d=8mm	d=12mm	d=1/2"					
Assembly	RG20005			41.0	22.0			70
		RG20002	RG20008	41.0	22.0			76
Components								
1. Profile cutter	RG20000	RG20000	RG20000	41.0			11	
2. Cutter	NG41060	NG41060	NG41060	41.0		6.3		
Ball Bearing	B220080	B220080	B220080					
Arbor & Nut	NG00005	NG00002	NG00008					

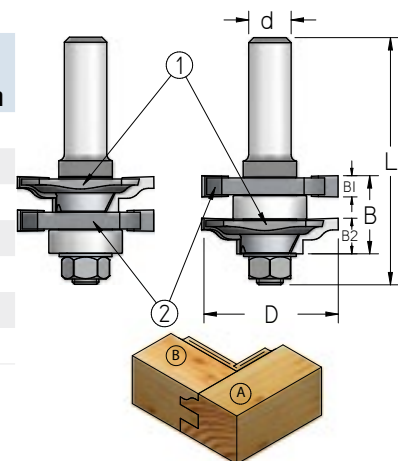
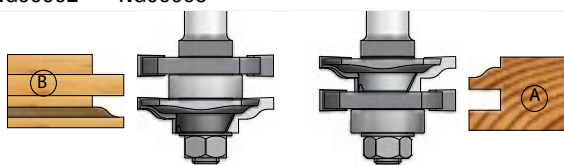

RG3

Ogee

Description	Tool No.			D	B	B1	B2	L
	d=8mm	d=12mm	d=1/2"					
Assembly	RG30005			46.0	22.0			70
		RG30002	RG30008	46.0	22.0			76
Components								
1. Profile cutter	RG30000	RG30000	RG30000	46.0			15	
2. Cutter	NG46040	NG46040	NG46040	46.0		4		
Ball Bearing	B220080	B220080	B220080					
Arbor & Nut	NG00005	NG00002	NG00008					

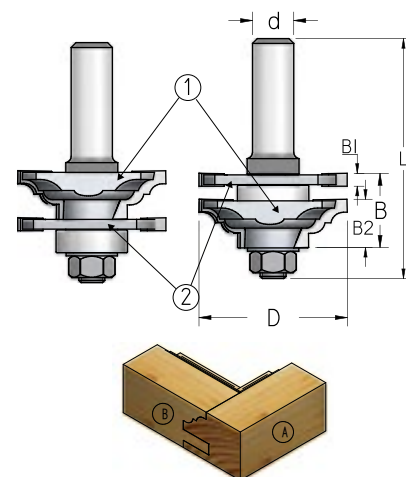
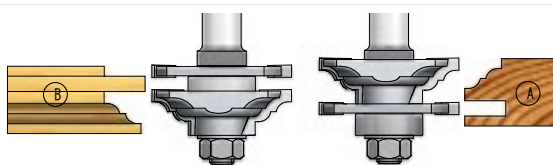

RG5

Traditional

Description	Tool No.			D	B	B1	B2	L
	d=8mm	d=12mm	d=1/2"					
Assembly	RG50005			41.0	22.0			70
		RG50002	RG50008	41.0	22.0			76
Components								
1. Profile cutter	RG50000	RG50000	RG50000	41.0			11	
2. Cutter	NG41060	NG41060	NG41060	41.0		6.3		
Ball Bearing	B220080	B220080	B220080					
Arbor & Nut	NG00005	NG00002	NG00008					

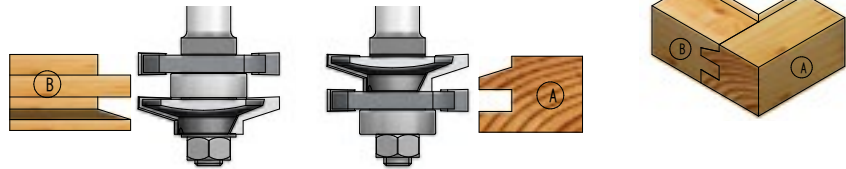
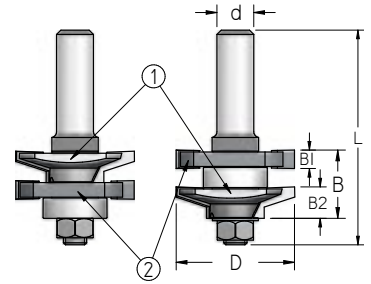

RG6

Tongue & Groove Cutter Set

By changing the components of the assembly, you can use a single tool for both cuts A&B.

Description	Tool No.			D	B	B1	L
	d=8mm	d=12mm	d=1/2"				
Assembly	RG60005	RG60002	RG60008	41.0	19.0		72
Components							
Cutter (x2)	NG41060	NG41060	NG41060	41.0		6.3	
Ball Bearing	B220080	B220080	B220080				
Arbor & Nut	NHRG815	NHRG812	NHRG818				

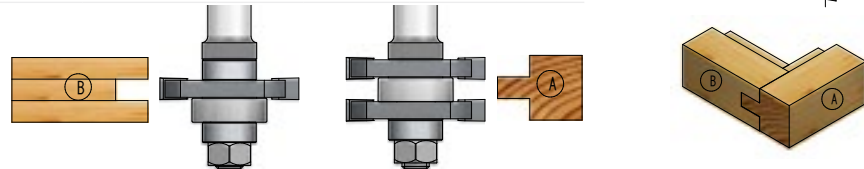
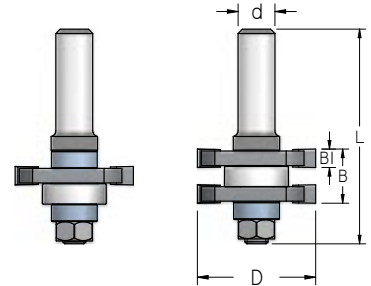

N3

Slotting Cutters 3 Wings

The assemblies include a cutter, arbor and bearing.

B mm	Cutter Tool No.	Assembly No.				
		d=6mm	d=1/4"	d=8mm	d=12mm	d=1/2"
1.5	N301500	N301583	N301584	N301585	N301582	N301588
1.6	N301600	N301683	N301684	N301685	N301682	N301688
2.0	N302000	N302083	N302084	N302085	N302082	N302088
2.4	N302400	N302483	N302484	N302485	N302482	N302488
2.5	N302500	N302583	N302584	N302585	N302582	N302588
3.0	N303000	N303083	N303084	N303085	N303082	N303088
3.2	N303200	N303283	N303284	N303285	N303282	N303288
4.0	N304000	N304083	N304084	N304085	N304082	N304088
4.8	N304800	N304883	N304884	N304885	N304882	N304888
5.0	N305000	N305083	N305084	N305085	N305082	N305088
6.0	N306000	N306083	N306084	N306085	N306082	N306088
6.3	N306300	N306383	N306384	N306385	N306382	N306388

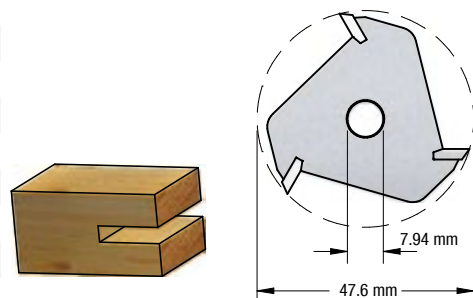
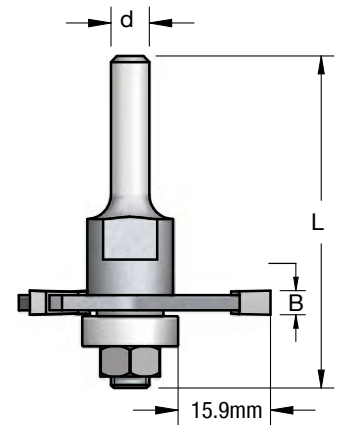

For all Arbors for Slotting Cutters see page 80.



NB

“Biscuit” Jointer Assembly

Includes slotting cutter, arbor and ball bearing guide.

d=6mm	Tool No. d=1/4"	d=8mm	For Biscuit No.	A mm	Bearing
NB15003	NB15004	NB15005	0	9	B220060
NB19003	NB19004	NB19005	10	10.5	B190060
NB23003	NB23004	NB23005	20	12.5	B150060

Components

1. Arbor & Nut

NB06003	NB06004	NB06005
---------	---------	---------

2. Cutter (2 wings)

N204030	N204030	N204030
---------	---------	---------

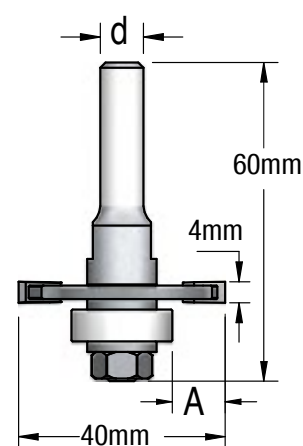

NBS

Set for all 3 sizes of biscuits

Includes slotting cutter, arbor and 3 ball bearing guides.

d=6mm	Set No. d=1/4"	d=8mm
NBS0303	NBS0304	NBS0305



NBC

“Biscuit” Jointer Cutter

Produces 4mm slots for plate jointing machines like Lamello, Virutex DeWalt etc.
6 Flutes

Tool No.	D mm	d mm	B mm
2 flutes – Positive shear angle, 4 Flutes – Negative shear angle			
NBC6010	100	22	4
All flutes with Positive shear angle			
NBC6020	100	22	4

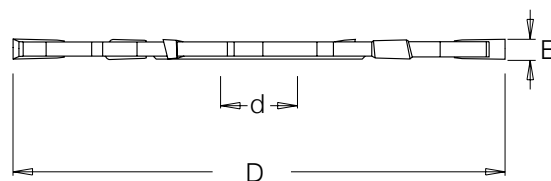
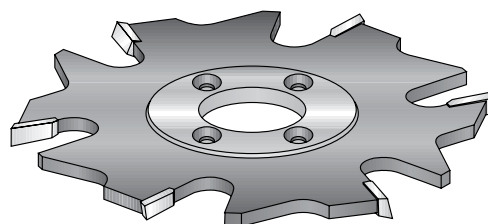

NS

Variable Depth Set for Slotting Cutters

Includes arbor and 5 ball bearings for changing cut depths.
All Slotting cutters N3 type can be used. Cutter not included.

Set No.			C	Ball Bearing	L
d=6mm	d=1/4"	d=8mm	mm		mm
			2.8	B420150	
			6.3	B350150	
NS79053	NS79054	NS79055	7.8	B320150	70
			9.8	B280150	
			12.8	B220080	

Set No.		C	Ball Bearing	L
d=12mm	d=1/2"	mm		mm
		2.8	B420150	
		6.3	B350150	
NS79052	NS79058	7.8	B320150	78
		9.8	B280150	
		12.8	B220080	

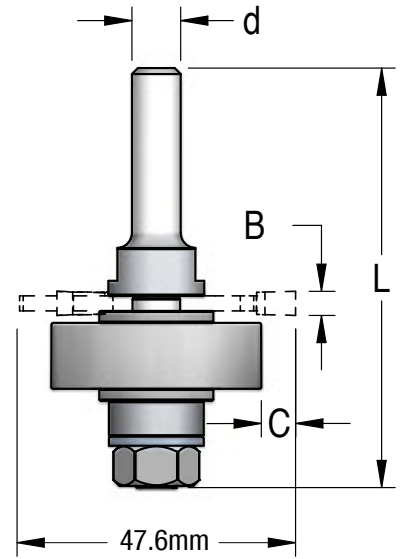

NUS

Slot & Undercut Bit with Variable Depth

For general Slotting and undercutting. Suitable for flooring.
Exchangeable bearings enable achieving different depths of cut.
All assemblies are supplied with Torx Key T25.

B mm	Cutter Tool No.	Assembly No.		
		d=8mm	d=12mm	d=1/2"
Includes Cutter and arbor				
3.0	N3U0300	NU03005*	NU03002*	NU03008*
4.0	N3U0400	NU04005	NU04002	NU04008
5.0	N3U0500	NU05005	NU05002	NU05008
6.0	N3U0600	NU06005	NU06002	NU06008
Includes Cutter, arbor and 4 bearings				
3.0	N3U0300	NUS03045**	NUS03042**	NUS03048**
4.0	N3U0400	NUS04045	NUS04042	NUS04048
5.0	N3U0500	NUS05045	NUS05042	NUS05048
6.0	N3U0600	NUS06045	NUS06042	NUS06048

*For NU03005/2/8 use the corresponding arbor - NU79005/2/8
**For NU03045/2/8 use the corresponding arbor - NU79005/2/8
Replacement Torx screw - BT50080

Arbors for Slot & Undercut Bit

Tool No.			L
d=8mm	d=12mm	d=1/2"	mm
NU79015			57
	NU79012	NU79018	67

Table for Choosing the bearing according to the desired slot

Ball Bearing	B420150	B350150	B320150	B280150
Slot Depth (C)	2.8 mm	6.3 mm	7.8 mm	9.8 mm

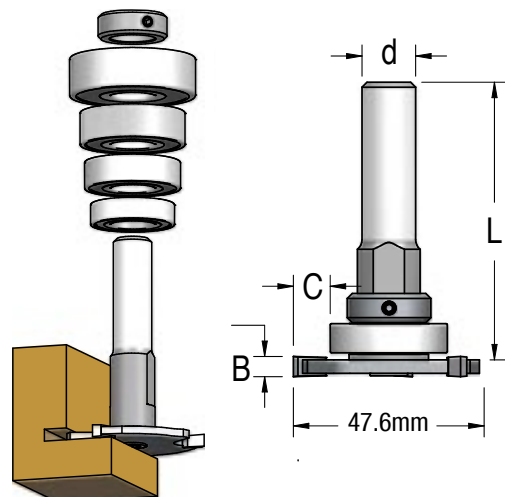
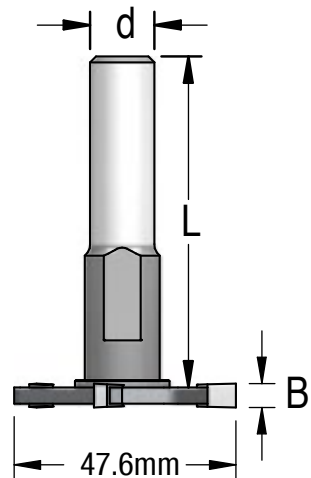

FJ2

Glue Joint Bit

Tool No.		D	B	L
d=12mm	d=1/2"	mm	mm	mm
FJ20002	FJ20008	47.0	28	66

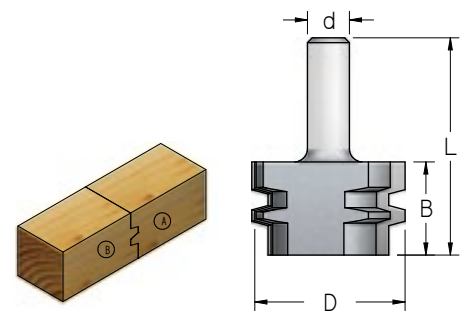
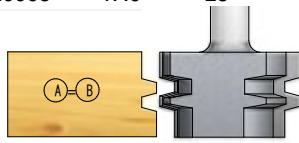

FJ4

45° Lock Mitre Joint Bit

Tool No.		a	D	B	L
d=12mm	d=1/2"	degrees	mm	mm	mm
FJ40002	FJ40008	45	67.0	30	69

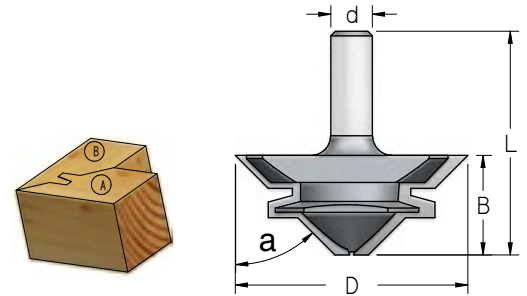
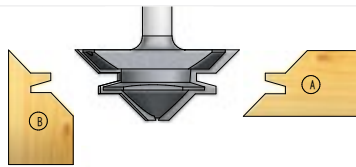

FJ5

Combi Joint Set

Assembly with Ball Bearing Guide.

Description	Tool No.		D	A	B	B1	L
	d=12mm	d=1/2"	mm	mm	mm	mm	mm
Assembly	FJ50002	FJ50008	47.6		36.0		96
Components							
Cutter (x5)	N304000	N304000	47.6			4.0	
Arbor & Nut	NFJ5002	NFJ5008					
Delrin Set	BDEL500	BDEL500		9.8			
Delrin Set	BDEL510	BDEL510		9.3			
Delrin Set	BDEL520	BDEL520		6.8			

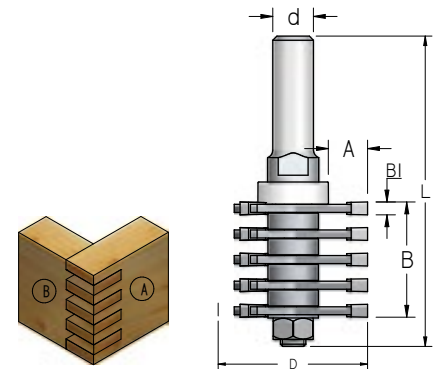
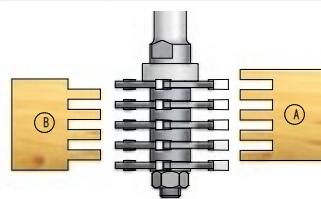

FJ6

Finger Joint Set

Assembly with Ball Bearing Guide.

Description	Tool No.		D	B	B1	L
	d=12mm	d=1/2"	mm	mm	mm	mm
Assembly	FJ60002	FJ60008	39.5	33.0		96
Components						
1.Cutter (x5)	NJ39020	NJ39020	39.5		1.9	
2.Cutter (x1)	NJ39050	NJ39050	39.1		5.5	
Arbor & Nut	NFJ6002	NFJ6008				
Ball Bearing	B280080	B280080				

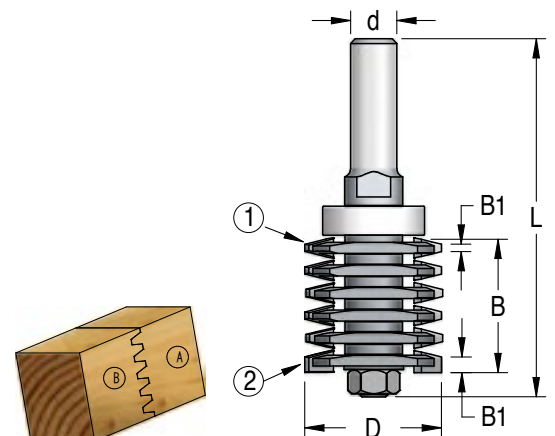
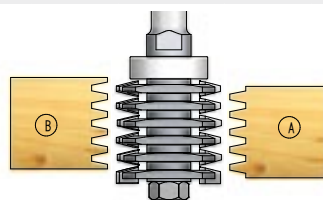

WOODPECKER

Economical line of quality carbide tipped router bits - essential for every craftsman and DIY amateur. A basic assortment of router bits and sets. The tools facilitate renovations, repairs and restoration of furniture. Excellent for building furniture and artistry on wood. Available with 6mm shank, 8mm shank and 1/4" shank.



Woodpecker Router Bits

Economical line of quality carbide tipped router bits



HP

Straight Bits

Tool No.		D	B	L	
d=6mm	d=1/4"	d=8mm	mm	mm	
HP21053	HP21054	HP21055	5	12	48
HP23063	HP23064	HP23065	6	20	48
HP23083	HP23084	HP23085	8	20	48
HP24083	HP24084	HP24085	8	25	56
HP23103	HP23104	HP23105	10	20	48
HP23123	HP23124	HP23125	12	20	48
HP24123	HP24124	HP24125	12	25	56
HP23133	HP23134	HP23135	12.7	20	48
HP23143	HP23144	HP23145	14	20	48
HP23163	HP23164	HP23165	16	20	48
HP23183	HP23184	HP23185	18	20	48
HP23193	HP23194	-	19	20	48
HP23203	HP23204	HP23205	20	20	48
HP23253	HP23254	-	25	20	48

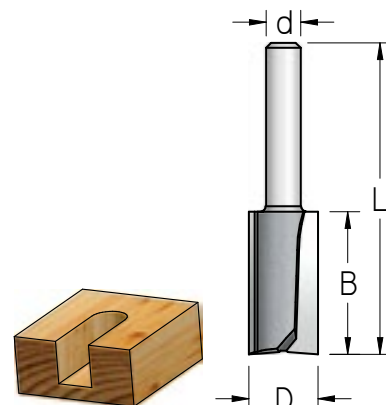

HF

Flush Trimming Bits

Tool No.		D	B	L	Bearing	
d=6mm	d=1/4"	d=8mm	mm	mm	mm	
HF22093	HF22094	HF22095	9.5	13	53	B095032
HF24093	HF24094	HF24095	9.5	25	65	B095032
HF22123	HF22124	HF22125	12.7	13	53	B127048
HF24123	HF24124	HF24125	12.7	25	65	B127048

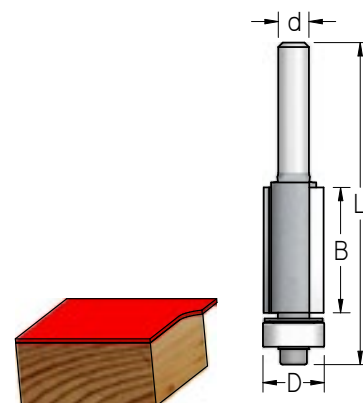

HPF

Straight Plunge Template Bits

Tool No.		D	B	L	Bearing	Retaining Collar	
d=6mm	d=1/4"	d=8mm	mm	mm	mm	mm	
HPF4123	HPF4124		12.7	25	63	B127063	PF06300
HPF4163	HPF4164		16	25	63	B127063	PF06300
		HPF4165	16	25	63	B160080	PF08000

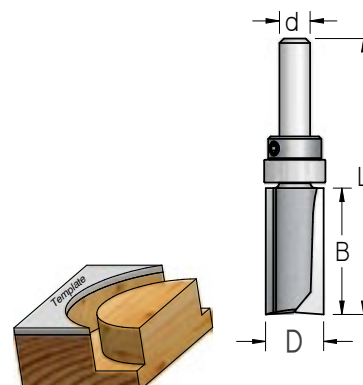

HSL

Bevel Trimming Bits

Tool No.		a	B	L	Bearing	
d=6mm	d=1/4"	d=8mm	degrees	mm	mm	
HSL1503	HSL1504	HSL1505	15	6.5	51	B127048
HSL2253	HSL2254	HSL2255	25	6.5	46.5	B095032
HSL4503	HSL4504		45	6.5	52.5	B127048
HSL2453	HSL2454	HSL2455	45	13	50	B095032

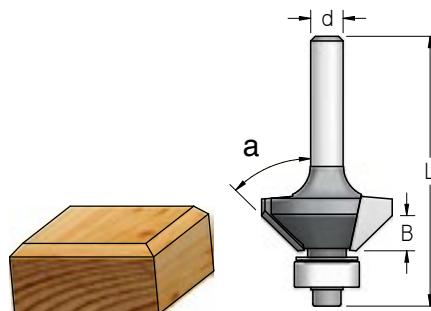

HE

Rabbeting Bits

Tool No.		C	D	B	L	Bearing	
d=6mm	d=1/4"	d=8mm	mm	mm	mm	mm	
HE22033	HE22034	HE22035	4.8	18.8	11	46	B095048
HE22103	HE22104	HE22105	9.5	28.6	12	47	B095032
HE22093	HE22094	HE22095	11.1	31.8	12	46.5	B095048

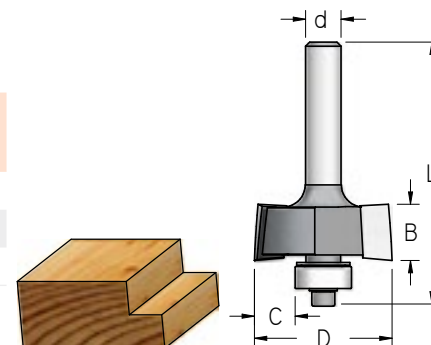

HES

Rabbeting & Flush Trim Set

2 bits - 4 bearing guides
Allows 8 different cuts

Tool No.		D	B	L	C	Bearing	
d=6mm	d=1/4"	d=8mm	mm	mm	mm	mm	
HES8003	HES8004	HES8005					
Components							
					0-flush	B190048	
HE22033	HE22034	HE22035	18.8	11	46	1.6	B160048
						3.2	B127048
						4.8	B095048
						6.3	B190048
HE22093	HE22094	HE22095	31.8	12	46	8.0	B160048
						9.5	B127048
						11.1	B095048

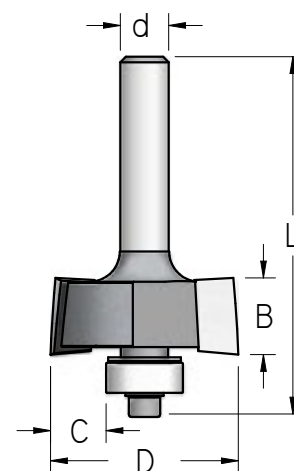

HZ

Dovetail Bit

Tool No.		a	D	B	L
d=6mm	d=1/4"	d=8mm	degrees	mm	mm
HZ13143	HZ13144	HZ13145	14	12.7	45

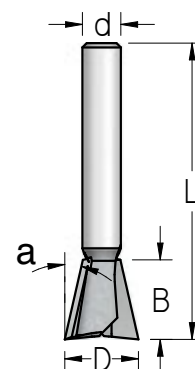
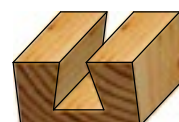

HV**"V"- Grooving Bits**

Tool No.		a	D	B	L	
d=6mm	d=1/4"	d=8mm	degrees	mm	mm	mm
HV60953	HV60954	HV60955	60	9.5	10	41
HV90123	HV90124	HV90125	90	12.7	8	38

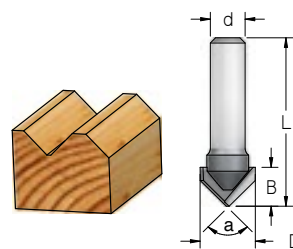
**HRB****Core Box Bits**

Tool No.		R	D	B	L	
d=6mm	d=1/4"	d=8mm	mm	mm	mm	mm
HRB0603	HRB0604	HRB0605	3.2	6.3	5	42
HRB1003	HRB1004	HRB1005	4.8	9.5	6	38
HRB1203	HRB1204	HRB1205	6.3	12.7	8	39
HRB1903	HRB1904	HRB1905	9.5	19	11	44

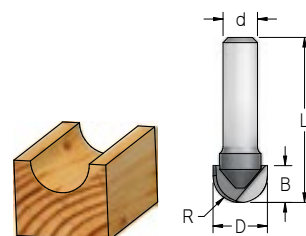
**HRC****Classical Bit**

Tool No.		R	R1	D	B	L	
d=6mm	d=1/4"	d=8mm	mm	mm	mm	mm	
HRC0303	HRC0304	HRC0305	4.0	3.2	12.7	8	38

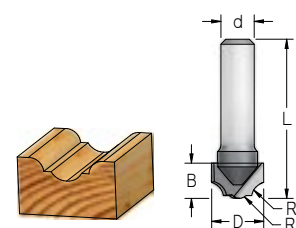
**HRD****Roman Ogee Bits**

Tool No.		R	D	B	L	Bearing	
d=6mm	d=1/4"	d=8mm	mm	mm	mm	mm	
HRD0403	HRD0404	HRD0405	4.0	25	16	52	B095032
HRD0603	HRD0604	HRD0605	6.3	35	19	57.5	B095032

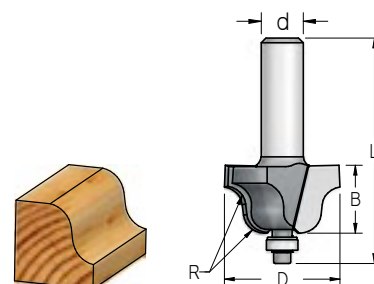
**HRZ****Cove Bits**

Tool No.		R	D	B	L	Bearing	
d=6mm	d=1/4"	d=8mm	mm	mm	mm	mm	
HRZ0603	HRZ0604	HRZ0605	6.3	22	13	49	B095032
HRZ1003	HRZ1004	HRZ1005	9.5	28.6	14	51	B095032
HRZ1203	HRZ1204	HRZ1205	12.7	35	15	54	B095032

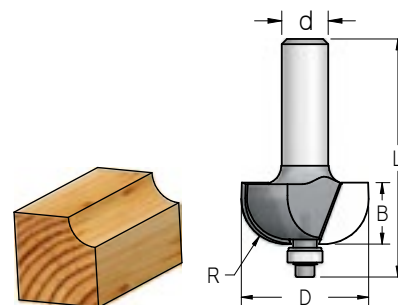
**HRJ****Wavy Edge Bit**

Tool No.		R	D	B	L	Bearing	
d=6mm	d=1/4"	d=8mm	mm	mm	mm	mm	
HRJ0303	HRJ0304	HRJ0305	3	25	13	47.5	B095032

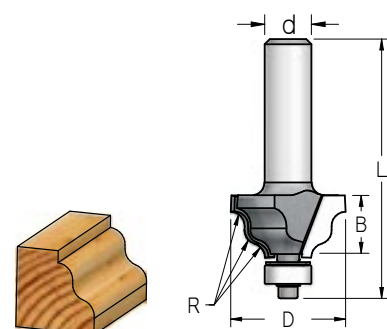

HRW

Rounding Over Bits

Tool No.			R	D	D1	B	L	Bearing
d=6mm	d=1/4"	d=8mm	mm	mm	mm	mm	mm	
HRW0303	HRW0304	HRW0305	3.2	15.8	9.5	10	45	B095032
HRW0603	HRW0604	HRW0605	6.3	22	9.5	13	47	B095032
HRW0803	HRW0804	HRW0805	8	25	9.5	15	49	B095032
HRW1003	HRW1004	HRW1005	9.5	28.6	9.5	17	51	B095032
HRW1213	HRW1214	HRW1215	12.7	38	12.7	17.5	59	B127048

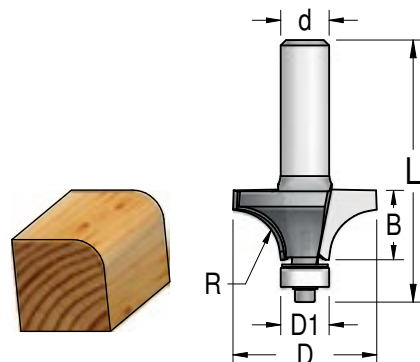

HRP

Beading Bits

Tool No.			R	D	D1	B	L	Bearing
d=6mm	d=1/4"	d=8mm	mm	mm	mm	mm	mm	
HRP0303	HRP0304	HRP0305	3.2	15.8	9.5	10	45	B063032
HRP0603	HRP0604	HRP0605	6.3	22	9.5	13	47	B063032
HRP0803	HRP0804	HRP0805	8	25	9.5	15	49	B063032
HRP1003	HRP1004	HRP1005	9.5	28.6	9.5	17	51	B063032
HRP1213	HRP1214	HRP1215	12.7	38	12.7	17.5	59	B095048

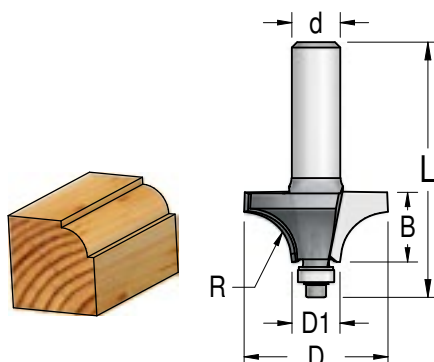

HS06

6 Pcs. Starter Set

In a handsome wooden storage box.

Set No.		
d=6mm	d=1/4"	d=8mm
HS06223	HS06224	HS06225
Consists of:		
HP23063	HP23064	HP23065
HP23123	HP23124	HP23125
HRD0403	HRD0404	HRD0405
HRP0603	HRP0604	HRP0605
HRW1003	HRW1004	HRW1005
HV90123	HV90124	HV90125



SA

Carbide Laminate Cutter

"Score and Break" for cutting laminates and other hard materials.
Can be used for glass.

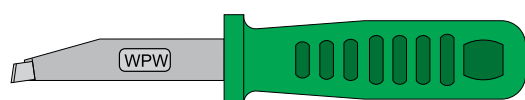

TOOL NO. SA00000



REPLACEMENT PARTS

Adapters, Ball Bearing guides, screws and other accessories for router machines and for router bits.



Replacement Parts

Accessories for CNC machines, router machines, router bits, countersinks and Drilling tools.

TX

Shank Extension Adapters

For CNC and Router machines. Allows deeper reach for a wide range of applications.

Very useful when the bit is too short for the job.

		Stock No.		D	W	SL	L
d=6mm	d=1/4"	d=8mm	d=12mm	d=1/2"	mm	mm	mm
TX03203	TX03204			3.17 (1/8")	11.1	28.5	57
TX06303	TX06304			6.35 (1/4")	16	28.5	67
		TX06302	TX06308	6.35 (1/4")	19	38	87
		TX08005		8	16	32	67
		TX12002		12	25.4	42	92
		TX12702	TX12708	12.7 (1/2")	25.4	42	92

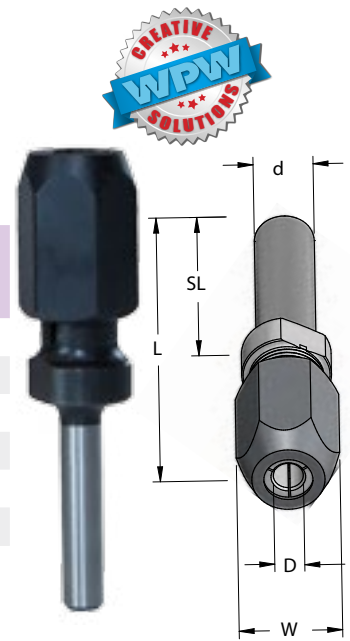

T/TL

Reduction Sleeves

For reducing collet size to take smaller shank.

Stock No	D mm	D1 mm	L mm
Single spring slot			
T060030	6	3	20
T060032	6	3.17 (1/8")	25
T060040	6	4	25
T063030	6.35 (1/4")	3	25
T063032	6.35 (1/4")	3.17 (1/8")	25
T063040	6.35 (1/4")	4.0	19
T063048	6.35 (1/4")	4.76 (3/16")	25
T080060	8	6	25
T080063	8	6.35 (1/4")	25
T095063	9.5 (3/8")	6.35 (1/4")	25
T095080	9.5 (3/8")	8	25
T100060	10	6	25
T100063	10	6.35 (1/4")	25
T100080	10	8	25
4 spring slots			
T120060	12	6	25
TL12063	12	6.35 (1/4")	30
T120080	12	8	25
T120100	12	10	25
T127032	12.7 (1/2")	3.17 (1/8")	25
T127048	12.7 (1/2")	4.76 (3/16")	25
TL12760	12.7 (1/2")	6	30
T127063	12.7 (1/2")	6.35 (1/4")	25
TL12763	12.7 (1/2")	6.35 (1/4")	30
T127080	12.7 (1/2")	8	25
TL12795	12.7 (1/2")	9.5	30
T127100	12.7 (1/2")	10	25

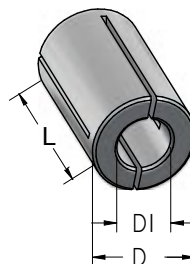
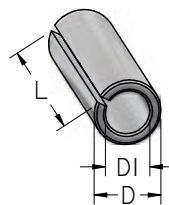

B

Ball Bearings

Stock No	D mm	D1 mm	B mm
B048024	4.76	2.38	2.4
B063032	6.35	3.17	2.8
B080040	8.00	4.00	3
B095032	9.53	3.17	4
B095048	9.53	4.76	3.2
B095063	9.53	6.35	3.2
B100050	10.00	5.00	4
B110050	11.00	5.00	4
B120060	12.00	6.00	4
B120080	12.00	8.00	3.5
B124048*	12.40	4.76	5
B127048	12.70	4.76	5
B127063	12.70	6.35	4.8
B150060	15.00	6.00	5
B159063	15.87	6.35	5
B160048	15.87	4.76	5

Stock No	D mm	D1 mm	B mm
B160050	16.00	5.00	5
B160080	16.00	8.00	5
B190048	19.05	4.76	6
B190060	19.00	6.00	6
B190063	19.05	6.35	7.1
B190127	19.05	12.70	4
B220060	22.00	6.00	7
B220080	22.00	8.00	7
B254127	25.40	12.70	6
B260100	26.00	10.00	8
B280150	28.00	15.00	7
B285127	28.57	12.70	8
B320150	32.00	15.00	9
B350150	35.00	15.00	11
B420150	42.00	15.00	13

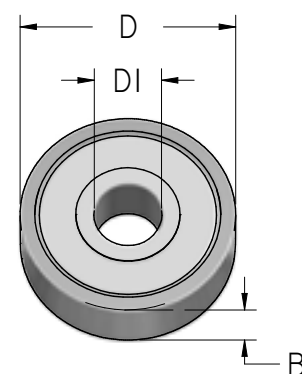

*undersized Bearing – for use after resharpening Router Bits

BD

Dust Shields

Mounted behind Ball Bearing in order to inhibit dust.

Stock No	D1 mm	D mm	Ball Bearing
BD08040	4	6.5	B080040
BD09532	3.2	9	B095032
BD09548	4.8	9	B095048
BD12748	4.8	12	B127048
BD16050	5	15	B160050
BD16063	6.4	15	B190063
BD35150	15	30	B350150

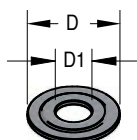

PF...O

Retaining Collars

Used for retaining Ball Bearings on Router Bit shanks.

Stock No	D1 mm	D mm	Screw No.
PF09500	6.35	9.3	BR32026
PF06300	6.35	11.0	BR32026
PF08010	8	11.5	BR32026
PF08000	8	14.0	BR32032
PF10000	10	16.0	BR32026
PF19000	12.7	18.5	BR32026
PF12700	12.7	23.0	BR48048
PF15000	15	23.0	BR48048

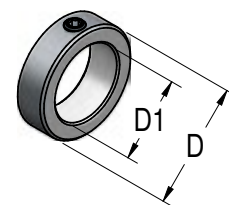

N

Arbors for Slotting Cutters

d=6mm		d=1/4"		Stock No.		D		D1		L	
				d=8mm	d=12mm	d=1/2"	mm	mm	mm	mm	mm
Arbor & Nut											
N000003	N000004	N000005					7.94	6.35	55		
				N000002	N000008		7.94	6.35	68		
Arbor, Nut and Bearing B159063											
N000803	N000804	N000805					7.94	6.35	55		
				N000802	N000808		7.94	6.35	68		
Arbor, Nut & Spacers											
N000013	N000014	N000015					7.94	-	70		
				N000012	N000018		7.94	-	78		
Arbor, Nut, spacers and bearing B220080											
N000813	N000814	N000815					7.94	-	70		
				N000812	N000818		7.94	-	78		

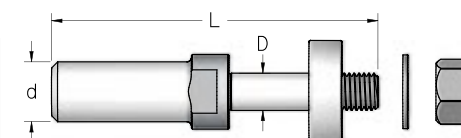
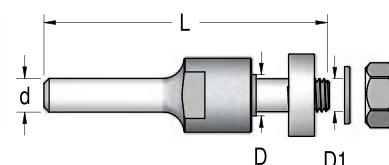

BR/BT

Screws

Stock No.	Description	Application	Fixing Key No.
Cap Screws			
BR25063	NC 3/48 x 6.3mm	Ball bearing fixing	KEY5/64
BR25095	NC 3/48 x 9.5mm	Ball bearing fixing	KEY5/64
BR30100	M3 x 10mm	Ball bearing fixing	KEY02.5
BR32095	NC 5/40 x 9.5mm	Ball bearing fixing	KEY3/32
BR40120	M4 x 12mm	ACM countersink and TATM	KEY03.0
BR48127	NF10-32 x 12.7mm	Ball bearing fixing	KEY04.0
Cap Screws with washer (SEMS)			
BRW2595	NC 3/48 x 9.5mm	Ball bearing fixing	KEY5/64
BRW3295	NC 5/40 x 9.5mm	Ball bearing fixing	KEY3/32
Set Screws			
BR32026	NC 5/40 x 2.6mm	Retaining Collars	KEY01.6
BR32032	NC 5/40 x 3.2mm	Retaining Collars	KEY01.6
BR40050	M4 x 5mm	Combi chuck adapters	KEY5/64
BR48048	NC 10/24 x 4.8mm	Countersinks & Counterbores	KEY3/32
BR50050	M5 x 5mm	Combi chucks	KEY02.5
BR50100	M5 x 10mm	Combi drills & adapters	Screwdriver (slot)
BR60050	M6 x 5mm	Countersinks & adapters	KEY03.0
BR60060	M6 x 6mm	Countersinks & Counterbores	KEY03.0
BR63040	NF1/4-28 x 4mm	Countersinks & Counterbores	KEY1/8
BR63048	NF1/4-28 x 4.8mm	Countersinks & Counterbores	KEY1/8
BR63063	NF1/4-28 x 6.3mm	Countersinks & Counterbores	KEY1/8
Torx Screws			
BT40056	Torx M4 x 5.6mm	Replaceable bits	KEY-TORX15
BT40060	Torx M4 x 6mm	Replaceable bits	KEY-TORX15
BT50080	Torx M5 x 8mm	Fixing Slot & Undercut bit	KEY-TORX25
Button Cap Screws			
BRK6363	NF1/4-28 x 6.3mm	Fixing Stopper on Countersink	KEY-4032

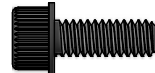
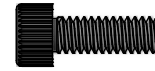

CM

Tungsten Carbide Replaceable Blades

For tools with replaceable Carbide blades.

Stock No	L mm	W mm	T mm	Cut. Edges	Holes
CM01212 /K	12	12	1.5	4	1
CM03012b /K	30	12	1.5	2	2
CM03012	29.5	12	1.5	4	2
CM05012b /K	50	12	1.5	2	2
CM05012	49.5	12	1.5	4	2
CM501217 /K	50	12	1.7	4	3

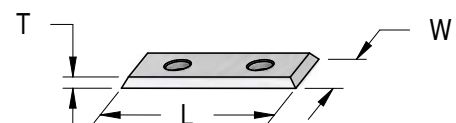

/K Can be ordered with Harder Grade. While ordering, just add the letter "K" at the end of the Stock No.

TECHNICAL INFORMATION

Technical information about router bits, including recommended cutting speeds, safety information etc.



Technical Information

Tungsten Carbide Tipped (TCT) tools (1) have carbide tips brazed onto a steel body. Solid Carbide tools are ground from a solid piece of Tungsten Carbide. Both are designed to cut hard and soft wood, chipboard, MDF, plywood, plastic, Corian and other solid surface sheet goods.



WPW TCT tools with "K-Carbide" grade have up to 200 % longer lifetime than tools with standard carbide. Developed especially for working on materials that consist of synthetic polymer resins for bonding purposes, the K- carbide is excellent for cutting MDF, HDF and other hard materials.

Solid Carbide Spiral CNC Bits (2) can work with higher feed rates and have longer tool life than TCT tools. These tools cut using less energy and with less vibration, leaving a perfect and clean finish on hardwood, softwood and man-made materials.

Aluminium and brass can also be cut, but only on stationary machines, provided that proper clamping devices are employed and the proper speed (RPM) and coolant are used.

Diamond Tipped PCD Router Bits (3) last 30- 50 times longer than Carbide tools and are very efficient in cutting abrasive materials including composites, particleboard, MDF and hardwoods.

Diamond Grit Coated Router Bits (4) are designed for cutting Fiberglass, Carbon Fiber and other Composite materials.

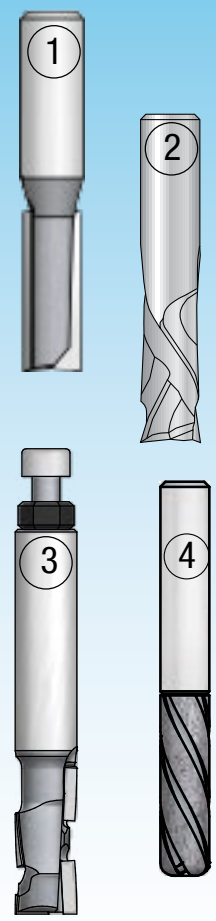

Shank and Collet

Always use the largest diameter shank available that your router will accommodate. Use the correct size collet. Proper collet condition is of extreme importance. Worn out or distorted collets do not provide adequate holding power and increase run-out and vibration. At least 3/4 of the shank length should be inserted into the collet. The best way is to insert it completely and then, back off slightly - 1.5mm approx.

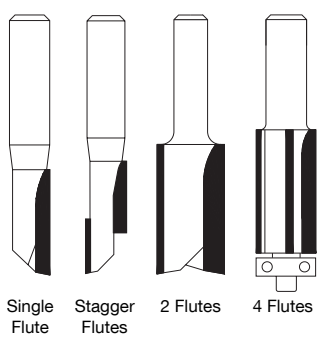

Flutes

When the routing is inside the material, more flutes mean less space for the chips to clear out. Higher "chip load" is created. This requires slowing down the feed rate. The chips, tend to get hot and the material being cut starts to burn and the bit overheats.

Single flute Bits are used for free cutting and roughing with fast feed rates.

Stagger-Tooth combine the fast stock removal of single-flute bits with a better balance and increased strength.

Double flute Router bits are good for roughing and finishing, and are the preferred choice for most woodworking jobs.

3 flute bits are better for finishing and have longer tool life while working on hard materials, such as solid surface materials or even aluminum. However, if the chips are not cleared fast enough, the feedrate must be slowed down.

4 flute bits are recommended when feeding the router along the outside edges of a work- piece, like in profiling jobs. They provide an extremely smooth finish.

Cutter Clearance - Relief

The relief on the carbide-cutting tip of straight router bits can be ground with either Radial Relief or Straight Relief.

Radial relief is preferred for professional applications, as it keeps a strong cutting edge, achieving longer lifetime. After resharpenering, it ensures that the Tool Diameter will be as close as possible to the original Diameter. WPW professional straight bits are ground this way to give the best possible performance.

Straight relief gives a sharper edge, it is more aggressive but it will not last as long. It is simpler to grind than the radial relief, but it is not recommended for working on hard materials. Our Woodpecker tools have a straight relief.

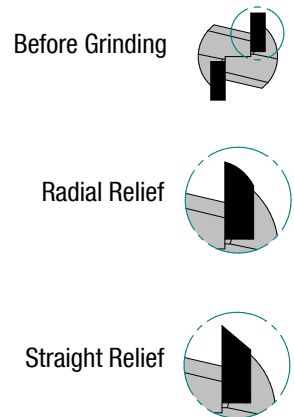

Shear Angle

Straight Shear Bits and Solid Carbide Spiral Bits are made with negative - “down shear” or positive - “up shear” angle of the cutting edges. By spreading the cutting action over a larger part of the tool, they produce smoother cuts with less energy and less vibration, than standard Straight Bits. This is the reason why profile router bits and cutters are usually made with an up shear angle, and this is also the advantage of straight spiral bits. Straight Shear Bits are a compromise between the standard Straight Bits and the expensive, industrial Solid Carbide Spiral Bits.

“Up shear” / Upcut geometry pulls the chips from the working area, allowing deep grooving and higher feed rates.

“Down shear” / Downcut geometry directs chips towards the work piece and results smoother cut and cleaner edge of laminated boards.

The combination of Upcut and Downcut design, also called: “Compression”, is suitable for perfect cutting with clean edges of double-sided laminated materials.

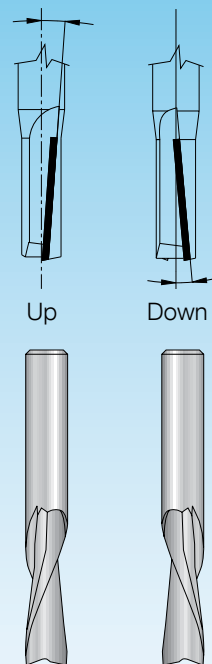

About Cutting and Router Speeds

We are often asked about recommended cutting speed for routing. The answer is complicated. The maximum allowed cutting speed for Carbide Router Bits depends on many factors such as:

1. Material type and hardness.
2. Stability of the system: machine, chuck, work piece.
3. Tool length and depth of cut.

The general formula for calculating Router speed (n) is:
$$n = \frac{V \times 60 \times 1000}{\pi \times \varnothing D}$$

n = router speed in RPM

V = cutting speed in meter/sec.

∅D = router bit's diameter in mm

π = 3.14...

RECOMMENDED CUTTING SPEED

Material	V
Softwood	60 - 90
Hardwood	50 - 80
Chipboard	60 - 80
Plywood	60 - 80
MDF	40 - 60
Laminates	40 - 60

This speed is not always practical. Taking into consideration the speed and the power of Router machines that are available in the market, we suggest the following router speeds in terms of RPM (Revolutions Per Minute).

SUGGESTED ROUTER SPEED - RPM

∅D	n (RPM)
Up to 25mm (1")	30,000
Up to 35mm (1-5/8")	28,000
Up to 50mm (2")	20,000
Up to 65mm (2-1/2")	18,000
Up to 80mm (3-1/4")	16,000
Up to 95mm (3-3/4")	12,000



WPW Router Bit Features

Strict Quality Control to precise standards.
Every tool undergoes inspection after production.

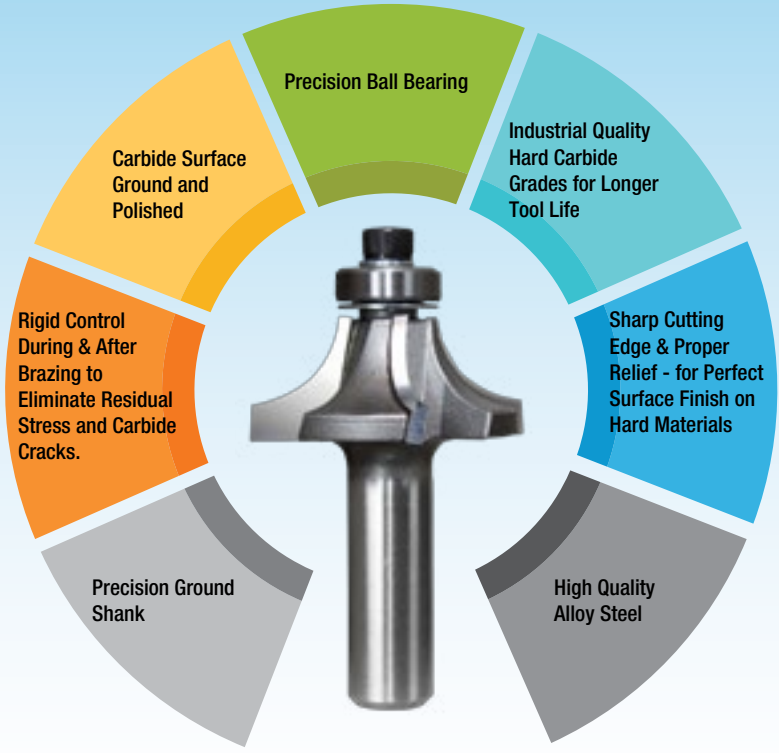

General Safety Information

Router machines running at high speeds can be dangerous, as the cutting tools may chip or fragment.

- Follow safety instructions supplied with your power tool.
Clean & dust machines regularly.
- Always wear eye, ear and respiratory protection while operating routers.
- Keep your fingers away from the tool while the machine is working.
- Unplug your router whenever changing the bit.
- Insert at least 3/4 of the shank into the collet.
- Do not cut too deep in one go. Feed router with suitable force in order to avoid overload.



- Feed router in correct direction - against the rotation of the bit.

- Remove the tool from the collet when not in use.
- Don't use worn out collets, and always use the correct size.
- Always have your cutting tool sharpened by a skilled worker using the proper grinding equipment.
- While resharpening tools, use adequate ventilation. The grinding process will produce dust that has potentially hazardous ingredients.



INDEX

ABB.....	11	FG.....	27	P2..XK.....	32	RT.....	61
AC2.....	13	FJ2.....	72	P3.....	34	RU.....	55
AC3.....	24	FJ4.....	72	P3F.....	39	RV.....	56
AC4.....	13	FJ5.....	72	P3U.....	34	RW.....	63
AC4..D.....	12	FJ6.....	72	PD.....	26	RWB.....	64
AC4M.....	13	FM.....	44	PF.....	38	RWG.....	64
ACD.....	14	FO.....	44	PF...0.....	80	RZ.....	61
ACF.....	24	FPM.....	41	PFM.....	40	SA.....	77
ACK.....	24	FP Multi Trimmers.....	41	PFS.....	39	SCC2.....	29
ACM.....	13	FPS.....	41	PFT.....	40	SCC3.....	29
ACO..D.....	12	FS.....	45	PG.....	27	SCF.....	51
ACO..M.....	10	FSG.....	45	P..L.....	33	SCF..W.....	51
ACO..T.....	12	FT.....	44	PL.....	17	SCPP.....	51
AF.....	14	FU.....	44	PLP.....	17	SCRB.....	52
AFP..M.....	10	HE.....	75	PP.....	50	SCS.....	29
ALB.....	11	HES.....	75	PP2.....	50	SCSL.....	51
AP2.....	13	HF.....	74	PPC.....	50	SCSL..W.....	51
AP4.....	13	HMP.....	15	PPS.....	50	SCU.....	29
AQP.....	11	HMPAL354.....	15	PPT.....	50	SCV.....	52
AQPS.....	17	HMPS.....	15	PS.....	34	SE.....	52
AS2.....	13	HMPT.....	15	PT.....	32	SL.....	45, 46
AS4..D.....	14	HMZ..0.....	18	PU.....	34	SL2.....	46
ASD.....	14	HMZ..4.....	18	QC.....	18	SL3.....	46
ASO..S.....	14	HP.....	74	QCS.....	17	SR1.....	26
ASO..T.....	14	HPF.....	74	RA.....	58	SR2.....	26
ATP.....	11	HRB.....	76	RB.....	55	SR3.....	26
B.....	80	HRC.....	76	RBL.....	56	ST.....	35
BD.....	80	HRD.....	76	RC.....	57	STD.....	35
BR.....	81	HRJ.....	76	RD.....	60	STP.....	35
BT.....	81	HRP.....	77	RF.....	64, 65	STS.....	35
BTAT.....	18	HRW.....	77	RG1.....	68	SZ.....	46
CM.....	81	HRZ.....	76	RG2.....	68	T.....	79
DB.....	56	HS06.....	77	RG3.....	68	TA.....	22, 23
DC.....	57	HSL.....	75	RG5.....	69	TAB.....	18
DDB.....	21	HV.....	76	RG6.....	69	TAC.....	12
DDT.....	21	HZ.....	75	RGD2.....	67	TAF080H.....	12
DL.....	59	MB.....	36	RGD5.....	67	TATM.....	19
DM.....	58	MB..0.....	36	RH.....	57	TATP.....	18
DR.....	19	MM.....	59	RJ.....	60	TDS.....	18
DRK.....	19	MN.....	16	RK.....	66	TK.....	22
DRS.....	19	MNK.....	16	RK04.....	66	TL.....	79
DRT.....	19	MNS.....	16	RK15.....	66	TM.....	23
DT.....	36	MNT.....	16	RK20.....	66	TX.....	79
E2.....	47	MP.....	15	RK40.....	66	UB2.....	37
E3.....	47	MPK.....	22	RK43.....	67	UB3.....	37
E4.....	47	N.....	80	RL.....	62	US2.....	37
E4S.....	49	N3.....	69	RM.....	61	US3.....	37
E33.....	48	NB.....	70	RN.....	62	V.....	53
EM.....	48	NBC.....	70	RO.....	65	VE.....	53
ES.....	48	NBS.....	70	RP.....	62	VG.....	54
F2.....	42, 43	NMB.....	36	RR.....	58, 59	Z.....	54
F3.....	43	NS.....	71	RRA.....	58	ZB.....	54
F4.....	43	NUS.....	71	RRC.....	58		
F4P.....	41	P1.....	33	RRI.....	59		
FD.....	27	P2.....	30, 31	RS.....	60		

Why should I become a WPW business partner?

- Professional quality – tested and approved
- Comprehensive range of tools
- Best carbide grades available
- Creative and experienced engineering team
- Advanced production
- Reliability and fast delivery
- Service above all
- Worldwide export for more than 50 years
- Excellent value for your money



26 Hahermesh St. Industrial Area, Karmiel

P.O.Box 6444, Karmiel 2165270 Israel

Tel: +972 4 998 9482 | Fax: +972 4 988 2817

www.wpw-tools.com | info@wpw.co.il

